

Features

- Wide 4.5V to 40V Input Voltage Range
- 5V,12V and adjustable versions
- Output Adjustable from 1.23V to 37V
- Maximum Duty Cycle 100%
- Minimum Drop Out 1.5V
- Fixed 52KHz Switching Frequency
- 3A Constant Output Current Capability
- Internal Optimize Power Transistor
- High efficiency
- Excellent line and load regulation
- TTL shutdown capability
- ON/OFF pin with hysteresis function
- Built in thermal shutdown function
- Built in current limit function
- Available in TO-220,TO-263 packages

General Description

The XL2576 is a 52 KHz fixed frequency PWM buck (step-down) DC/DC converter, capable of driving a 3A load with high efficiency, low ripple and excellent line and load regulation. Requiring a minimum number of external components, the regulator is simple to use and include internal frequency compensation and a fixed-frequency oscillator.

The PWM control circuit is able to adjust the duty ratio linearly from 0 to 100%. An enable function, an over current protection function is built inside. An internal compensation block is built in to minimize external component count.

Applications

- LCD Monitor and LCD TV
- Digital Photo Frame
- Set-up Box
- ADSL Modem
- Telecom / Networking Equipment

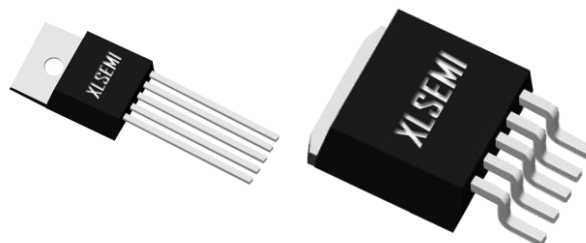

TO220-5L

TO263-5L

Figure1. Package Type of XL2576

Pin Configurations

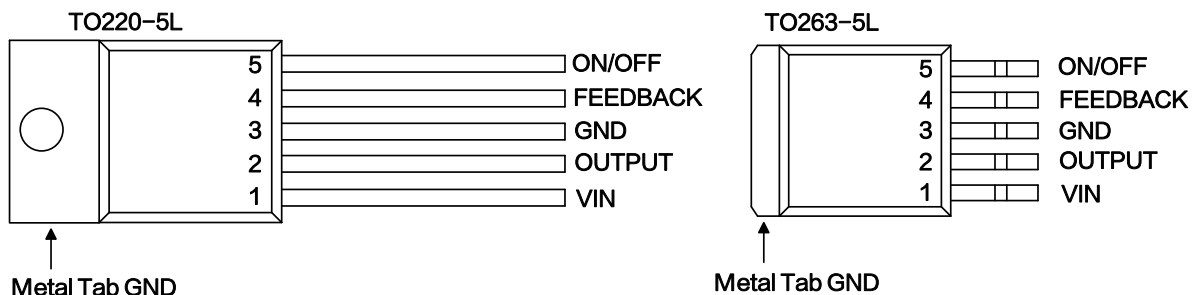

Figure2. Pin Configuration of XL2576 (Top View)

Table 1 Pin Description

Pin Number	Pin Name	Description
1	VIN	Supply Voltage Input Pin. XL2576 operates from a 4.5V to 40V DC voltage. Bypass Vin to GND with a suitably large capacitor to eliminate noise on the input.
2	OUTPUT	Power Switch Output Pin (SW). Output is the switch node that supplies power to the output.
3	GND	Ground Pin. Care must be taken in layout. This pin should be placed outside of the Schottky Diode to output capacitor ground path to prevent switching current spikes from inducing voltage noise into XL2576.
4	FEEDBACK	Feedback Pin (FB). Through an external resistor divider network, Feedback senses the output voltage and regulates it. The feedback threshold voltage is 1.23V.
5	ON/OFF	Enable Pin. Drive ON/OFF pin low to turn on the device, drive it high to turn it off. Floating is default low.

3A 52KHz 40V Buck DC to DC Converter

XL2576

Function Block

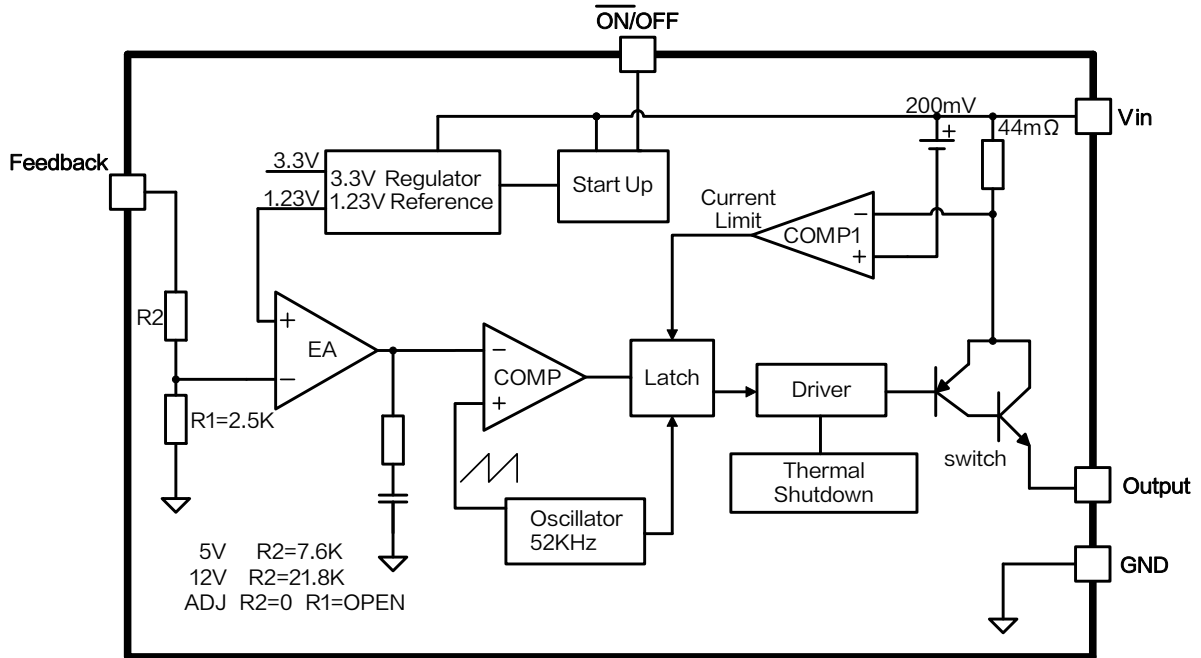

Figure3. Function Block Diagram of XL2576

Typical Application Circuit

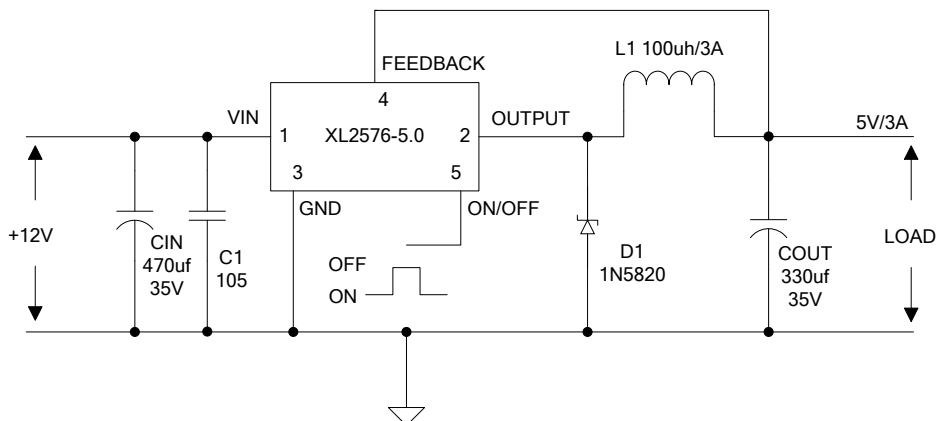
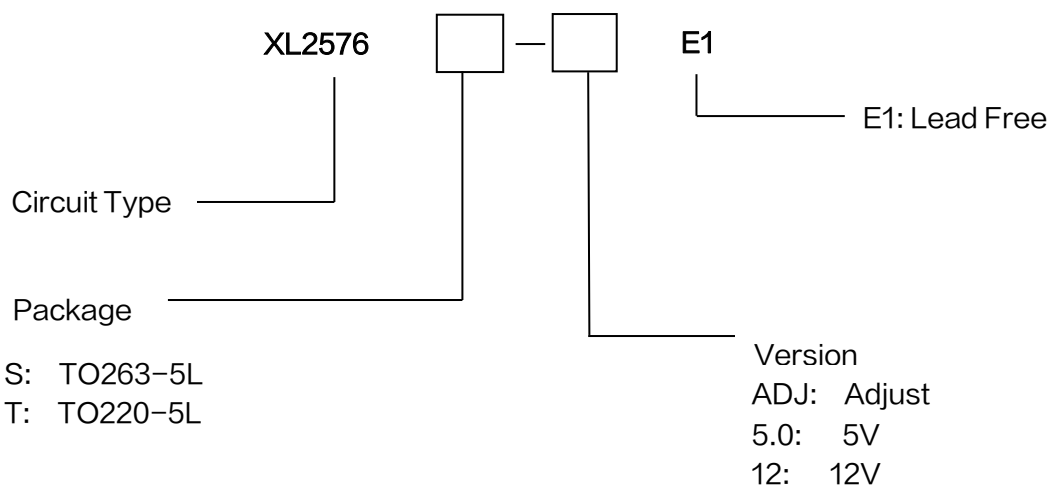

Figure4. XL2576 Typical Application Circuit 12V-5V/3A

3A 52KHz 40V Buck DC to DC Converter

XL2576

Ordering Information



Package	Temperature Range	Marking ID	Packing Type Supplied As
		Lead Free	
TO220-5L	-40°C ~ 85°C	XL2576T-ADJE1	Tube
		XL2576T-5.0E1	Tube
TO263-5L	-40°C ~ 85°C	XL2576S-ADJE1	800 Units on Tape & Reel
		XL2576S-5.0E1	800 Units on Tape & Reel
		XL2576S-12E1	800 Units on Tape & Reel

XLSEMI Pb-free products, as designated with “E1” suffix in the par number, are RoHS compliant.

3A 52KHz 40V Buck DC to DC Converter

XL2576

Absolute Maximum Ratings (Note1)

Parameter	Symbol	Value	Unit
Input Voltage	V_{in}	-0.3 to 45	V
Feedback Pin Voltage	V_{FB}	-0.3 to V_{in}	V
ON/OFF Pin Voltage	$V_{ON/OFF}$	-0.3 to V_{in}	V
Output Switch Pin Voltage	V_{Output}	-0.3 to V_{in}	V
Power Dissipation	P_D	Internally limited	mW
Thermal Resistance (TO220 & TO263) (Junction to Ambient, No Heatsink, Free Air)	R_{JA}	30	°C /W
Operating Junction Temperature	T_J	-40 to 125	°C
Storage Temperature	T_{STG}	-65 to 150	°C
Lead Temperature (Soldering, 10 sec)	T_{LEAD}	260	°C
ESD (HBM)		>2000	V

Note1: Stresses greater than those listed under Maximum Ratings may cause permanent damage to the device. This is a stress rating only and functional operation of the device at these or any other conditions above those indicated in the operation is not implied. Exposure to absolute maximum rating conditions for extended periods may affect reliability.

3A 52KHz 40V Buck DC to DC Converter

XL2576

XL2576–5.0 Electrical Characteristics

T_a = 25°C; unless otherwise specified.

Symbol	Parameter	Test Condition	Min.	Typ.	Max.	Unit
System parameters test circuit figure7						
VOUT	Output Voltage	V _{in} = 7V to 40V, I _{load} =0.2A to 3A	4.8	5	5.2	V
Efficiency	η	V _{in} =12V ,V _{out} =5V, I _{out} =3A	–	78	–	%

XL2576–12 Electrical Characteristics

T_a = 25°C; unless otherwise specified.

Symbol	Parameter	Test Condition	Min.	Typ.	Max.	Unit
System parameters test circuit figure5						
VOUT	Output Voltage	V _{in} = 15V to 40V, I _{load} =0.2A to 2A	11.52	12	12.48	V
Efficiency	η	V _{in} =24V ,V _{out} =12V, I _{out} =2A	–	92	–	%

XL2576–ADJ Electrical Characteristics

T_a = 25°C; unless otherwise specified.

Symbol	Parameter	Test Condition	Min.	Typ.	Max.	Unit
System parameters test circuit figure8						
VOUT	Output Voltage	V _{in} = 4.5V to 40V, I _{load} =0.2A to 3A	1.193	1.23	1.267	V
Efficiency	η	V _{in} =12V ,V _{out} =3V, I _{out} =3A	–	73	–	%

3A 52KHz 40V Buck DC to DC Converter

XL2576

Electrical Characteristics (DC Parameters)

$V_{in} = 12V$ for the 5V, and Adjustable versions and $V_{in} = 24V$ for the 12V version, $GND = 0V$, V_{in} & GND parallel connect a 220 μ F/50V capacitor; $I_{out} = 500mA$, $T_a = 25^{\circ}C$; the others floating unless otherwise specified.

Parameters	Symbol	Test Condition	Min.	Typ.	Max.	Unit
Input operation voltage	V_{in}		4.5		40	V
Shutdown Supply Current	I_{STBY}	$V_{ON/OFF} = 5V$		80	200	μ A
Quiescent Supply Current	I_q	$V_{ON/OFF} = 0V$, $V_{FB} = V_{in}$		2	10	mA
Oscillator Frequency	F_{osc}		40	52	64	KhZ
Switch Current Limit	I_L	$V_{FB} = 0V$	3.6	4.8	6.9	A
ON/OFF Pin Threshold	$V_{ON/OFF}$	High (Regulator OFF) Low (Regulator ON)		1.4 0.8		V
ON/OFF Pin Input Leakage Current	I_H	$V_{ON/OFF} = 2.5V$ (OFF)		5	15	μ A
	I_L	$V_{ON/OFF} = 0.5V$ (ON)		0.2	5	μ A
Output Saturation Voltage	V_{CE}	$V_{FB} = 0V$ $I_{out} = 3A$		1.3	1.5	V
Max. Duty Cycle	D_{MAX}	$V_{FB} = 0V$		100		%

Test Circuit and Layout guidelines

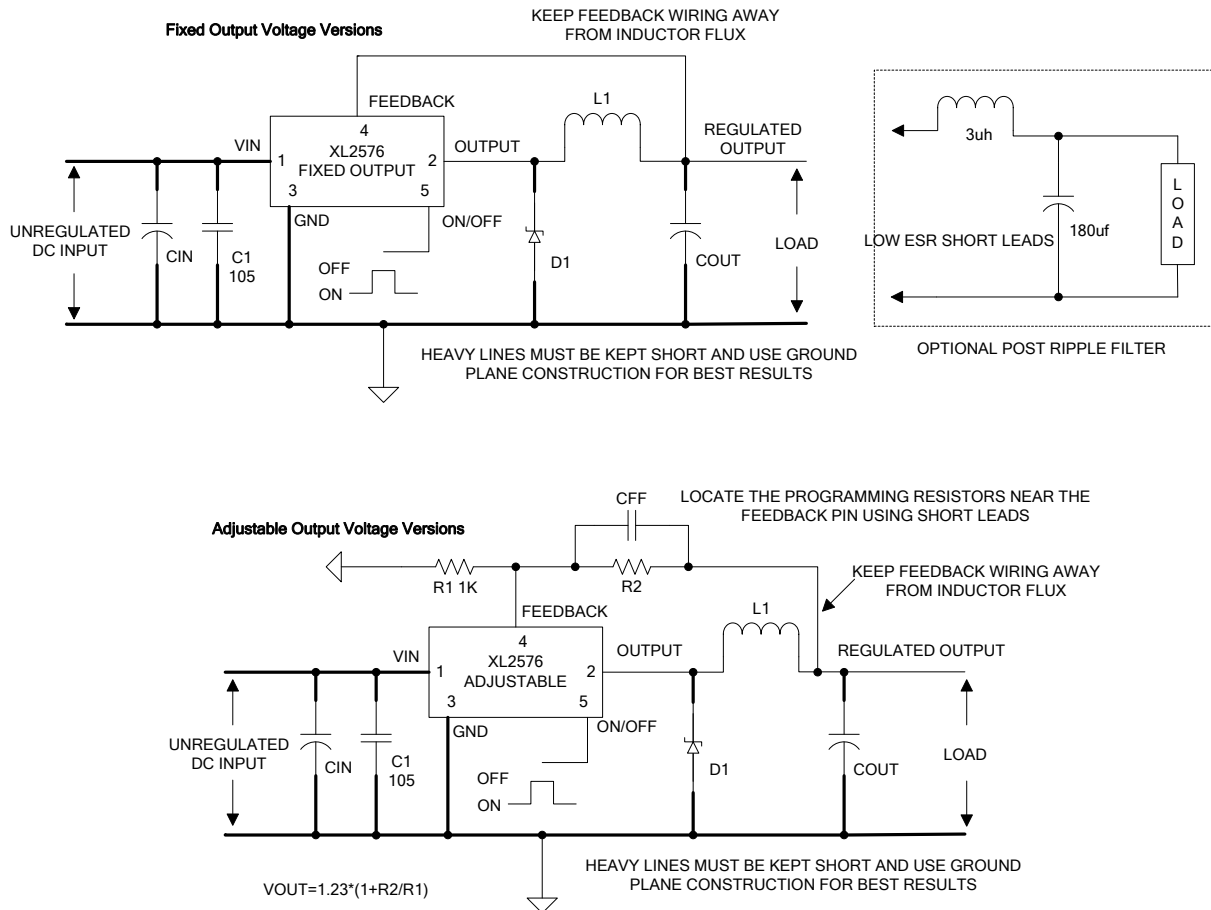

Figure5. Standard Test Circuits and Layout Guides

Select R1 to be approximately 1K, use a 1% resistor for best stability.

C1 and CFF are optional; in order to increase stability and reduce the input power line noise, CIN and C1 must be placed near to PIN1 and PIN3;

For output voltages greater than approximately 10V, an additional capacitor CFF is required. The compensation capacitor is typically between 100 pf and 33 nf, and is wired in parallel with the output voltage setting resistor, R2. It provides additional stability for high output voltage, low input-output voltages, and/or very low ESR output capacitors, such as solid tantalum capacitors.

$CFF = 1 / (31 * 1000 * R2)$; This capacitor type can be ceramic, plastic, silver mica, etc. (Because of the unstable characteristics of ceramic capacitors made with Z5U material, they are not recommended.)

3A 52KHz 40V Buck DC to DC Converter

XL2576

XL2576 Series Buck Regulator Design Procedure (Fixed Output)

Conditions			Inductor (L1)	Output Capacitor (COUT)			
Output Voltage (V)	Load Current (A)	Max Input Voltage (V)		Through Hole Electrolytic		Surface Mount Tantalum	
			Panasonic HFQ Series (uf/V)	Nichicon PL Series (uf/V)	AVX TPS Series (uf/V)	Sprague 595D Series (uf/V)	
5	3	7	47	470/25	560/16	220/10	330/10
		9	68	560/25	560/25	220/10	330/10
		15	100	330/35	330/35	220/10	330/10
		40	150	330/35	270/35	220/10	330/10
12	3	15	47	470/25	470/25	100/16	180/16
		18	68	330/25	330/25	100/16	180/16
		30	100	180/25	180/25	100/16	120/20
		40	150	180/35	180/25	100/16	120/20
	2	15	47	330/25	330/25	100/16	180/16
		20	100	180/25	180/25	100/16	120/20
		40	150	82/25	82/25	68/20	68/25

3A 52KHz 40V Buck DC to DC Converter

XL2576

XL2576 Series Buck Regulator Design Procedure (Adjustable Output)

Output Voltage (V)	Through Hole Output Electrolytic			Surface Mount Output Capacitor		
	Panasonic HFQ Series (uf/V)	Nichicon PL Series (uf/V)	Feedforward Capacitor	AVX TPS Series (uf/V)	Sprague 595D Series (uf/V)	Feedforward Capacitor
2	820/35	820/35	33nf	330/6.3	470/4	33nf
4	560/35	470/35	10nf	330/6.3	390/6.3	10nf
6	470/25	470/35	3.3nf	220/10	330/10	3.3nf
9	330/25	330/25	1.5nf	100/16	180/16	1.5nf
12	330/25	330/25	1nf	100/16	180/16	1nf
15	220/25	220/35	680pf	68/20	120/20	680pf
24	220/35	150/35	560pf	33/25	33/25	220pf
28	100/50	100/50	390pf	10/35	15/50	220pf

Schottky Diode Selection Table

Current	Surface Mount	Through Hole	VR (The same as system maximum input voltage)				
			20V	30V	40V	50V	60V
1A		✓	1N5817	1N5818	1N5819		
3A		✓	1N5820	1N5821	1N5822		
		✓	MBR320	MBR330	MBR340	MBR350	MBR360
	✓		SK32	SK33	SK34	SK35	SK36
	✓			30WQ03	30WQ04	30WQ05	
		✓		31DQ03	31DQ04	31DQ05	
		✓	SR302	SR303	SR304	SR305	SR306
5A		✓	1N5823	1N5824	1N5825		
		✓	SR502	SR503	SR504	SR505	SR506
		✓	SB520	SB530	SB540	SB550	SB560
	✓			50WQ03	50WQ04	50WQ05	

3A 52KHz 40V Buck DC to DC Converter	XL2576
--------------------------------------	--------

Typical System Application for 5V Version

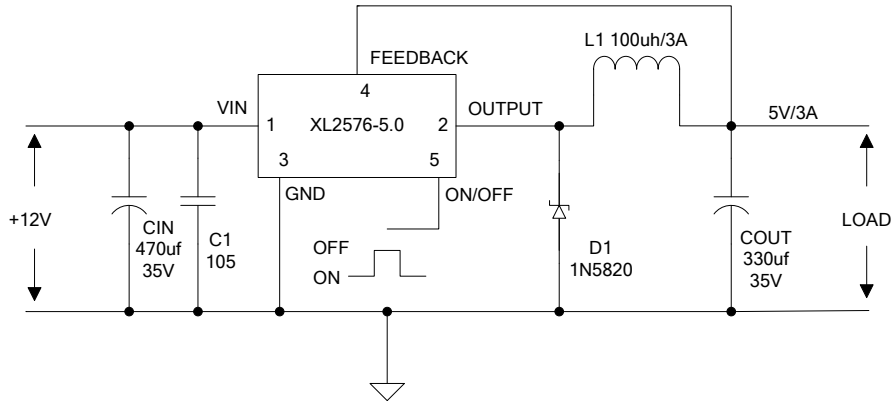

Figure6. XL2576-5.0 System Parameters Test Circuit

Typical System Application for 12V Version

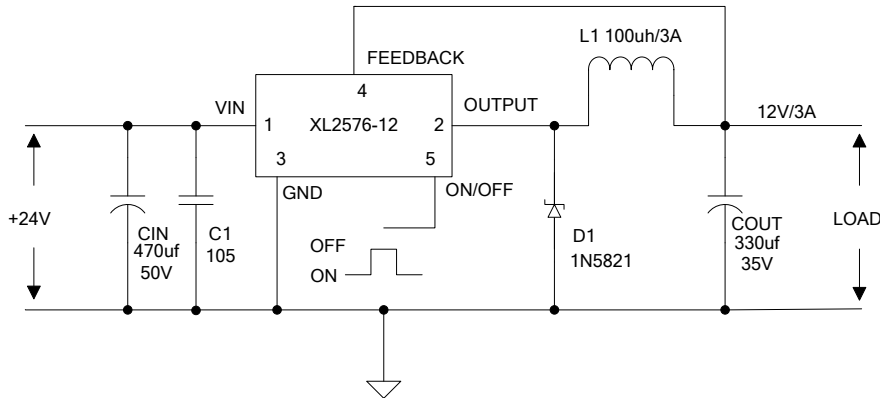

Figure7. XL2576-12 System Parameters Test Circuit

Typical System Application for ADJ Version

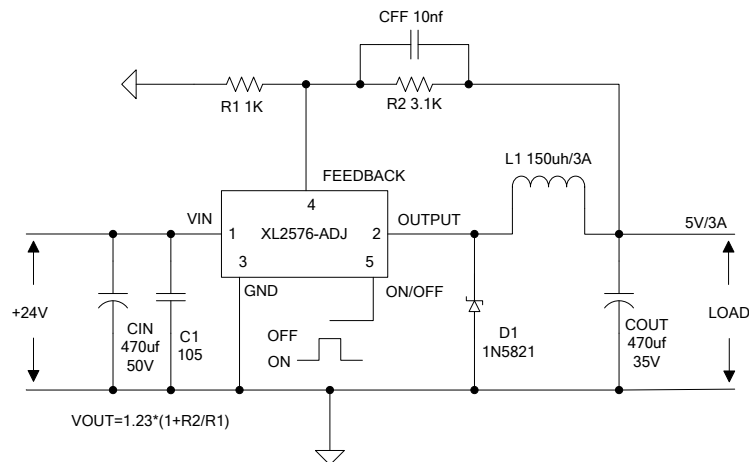
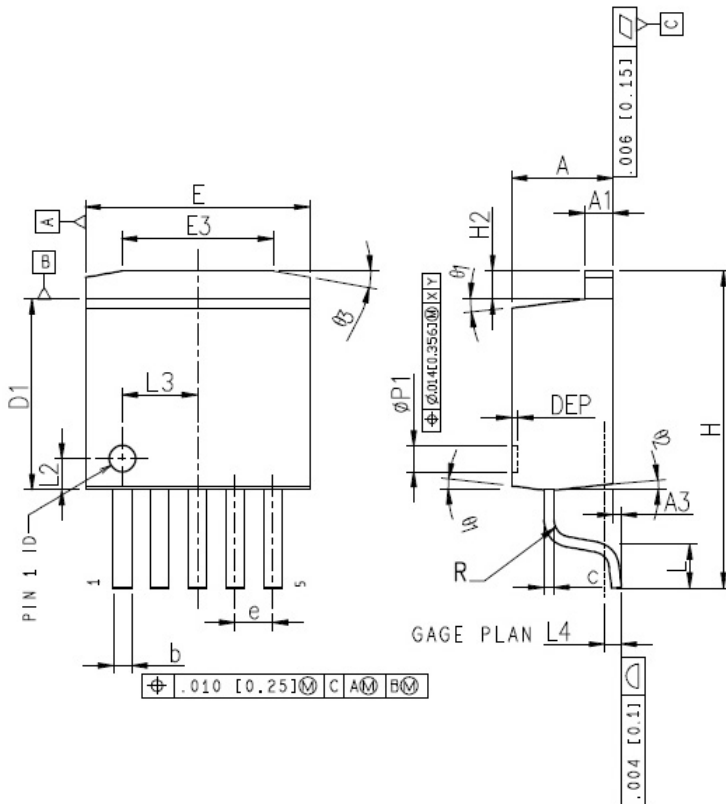

Figure8. XL2576-ADJ System Parameters Test Circuit

Package Information

(2) TO263-5L Mechanical Dimensions



COMMON DIMENSIONS						
SYMBOL	MM			INCH		
	MIN	NDM	MAX	MIN	NDM	MAX
A	4.45	4.57	4.70	0.175	0.180	0.185
A1	1.22	1.27	1.32	0.048	0.050	0.052
A3	0	-	0.15	0.000	-	0.006
b	0.71	-	0.97	0.028	-	0.038
c	0.38	-	0.76	0.015	-	0.030
D1	8.38	8.70	8.89	0.330	0.343	0.350
E	9.91	10.16	10.39	0.390	0.400	0.410
E1	10.03	10.16	10.54	0.395	0.400	0.415
E3	6.61	6.86	7.11	0.260	0.270	0.280
e	1.70BSC			0.067BSC		
H	-	-	14.35	-	-	0.565
H2	-	-	1.27	-	-	0.050
L	-	1.98	-	-	0.078	-
L2	1.47REF			0.058REF		
L3	3.40REF			0.134REF		
L4	-	0.76	-	-	0.030	-
φp1	1.07	1.20	1.32	0.042	0.047	0.052
R	-	-	0.76	-	-	0.030
θ1	-	7°	-	-	7°	-
θ2	-	3°	-	-	3°	-
θ3	7°	10°	13°	7°	10°	13°
θ4	-	3°	-	-	3°	-
DEP	0.10	0.18	0.25	0.004	0.007	0.010

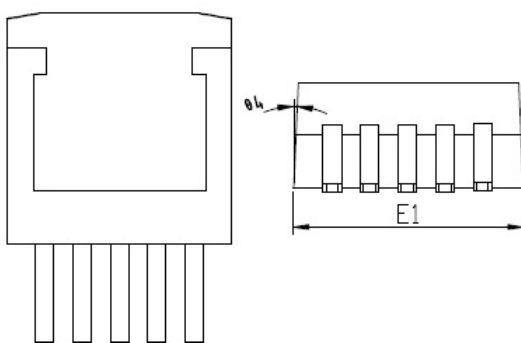

NOTES:
 1. ALL DIMENSIONS REFER TO JEDEC STANDARD TO-263, DO NOT INCLUDE MOLD FLASH OR PROTRUSIONS.

3A 52KHz 40V Buck DC to DC Converter**XL2576**

Important Notice

XLSEMI reserve the right to make modifications, enhancements, improvements, corrections or other changes without notice at any time. XLSEMI does not assume any liability arising out of the application or use of any product described herein; neither does it convey any license under its patent rights, nor the rights of others. XLSEMI assumes no liability for applications assistance or the design of Buyers' products. Buyers are responsible for their products and applications using XLSEMI components. To minimize the risks associated with Buyers' products and applications, Buyers should provide adequate design and operating safeguards. XLSEMI warrants performance of its products to the specifications applicable at the time of sale, in accordance with the warranty in XLSEMI's terms and conditions of sale of semiconductor products. Testing and other quality control techniques are used to the extent XLSEMI deems necessary to support this warranty. Except where mandated by applicable law, testing of all parameters of each component is not necessarily performed.

For the latest product information, go to www.xlsemi.com.