

Features

- Wide 8V to 40V Input Voltage Range
- Output Current Sense Voltage is 0.21V
- Maximum Duty Cycle 100%
- Minimum Drop Out 0.3V
- Fixed 220KHz Switching Frequency
- 3A Constant Output Current Capability
- Internal Optimize Power MOSFET
- High efficiency
- Excellent line and load regulation
- Built in thermal shutdown function
- Built in current limit function
- Available in SOP8-EP package

Applications

- Buck constant current driver
- Monitor LED Backlighting
- General purpose LED lighting

General Description

The XL3001 is a 220 KHz fixed frequency PWM buck (step-down) LED constant current driver, capable of driving a 3A load with high efficiency, low ripple and excellent line and load regulation. Requiring a minimum number of external components, the regulator is simple to use and include internal frequency compensation and a fixed-frequency oscillator.

The PWM control circuit is able to adjust the duty ratio linearly from 0 to 100%. An over current protection function is built inside. An internal compensation block is built in to minimize external component count.

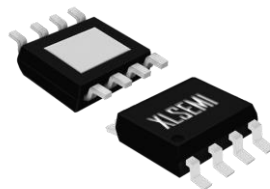

Figure1. Package Type of XL3001

Pin Configurations

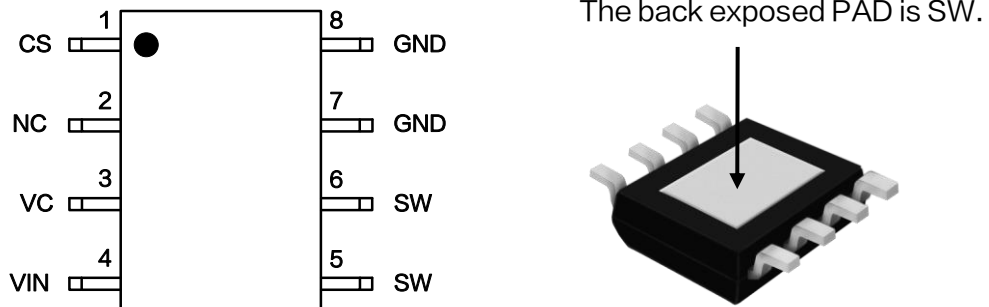

Figure2. Pin Configuration of XL3001

Table 1 Pin Description

Pin Number	Pin Name	Description
1	CS	Output constant current sense Pin (CS). The CS reference voltage is 0.21V.
2	NC	Not connected.
3	VC	Internal Voltage Regulator Bypass Capacitor Pin (VC). The VC pin connect a 1uf capacitor to VIN.
4	VIN	Supply Voltage Input Pin. XL3001 operates from a 8V to 40V DC voltage. Bypass Vin to GND with a suitably large capacitor to eliminate noise on the input.
5,6	SW	Power Switch Output Pin (SW). Output is the switch node that supplies power to the output. (Note: Connected the back exposed PAD to SW.)
7,8	GND	Ground Pin. Care must be taken in layout. This pin should be placed outside of the Schottky Diode to output capacitor ground path to prevent switching current spikes from inducing voltage noise into XL3001.

Function Block

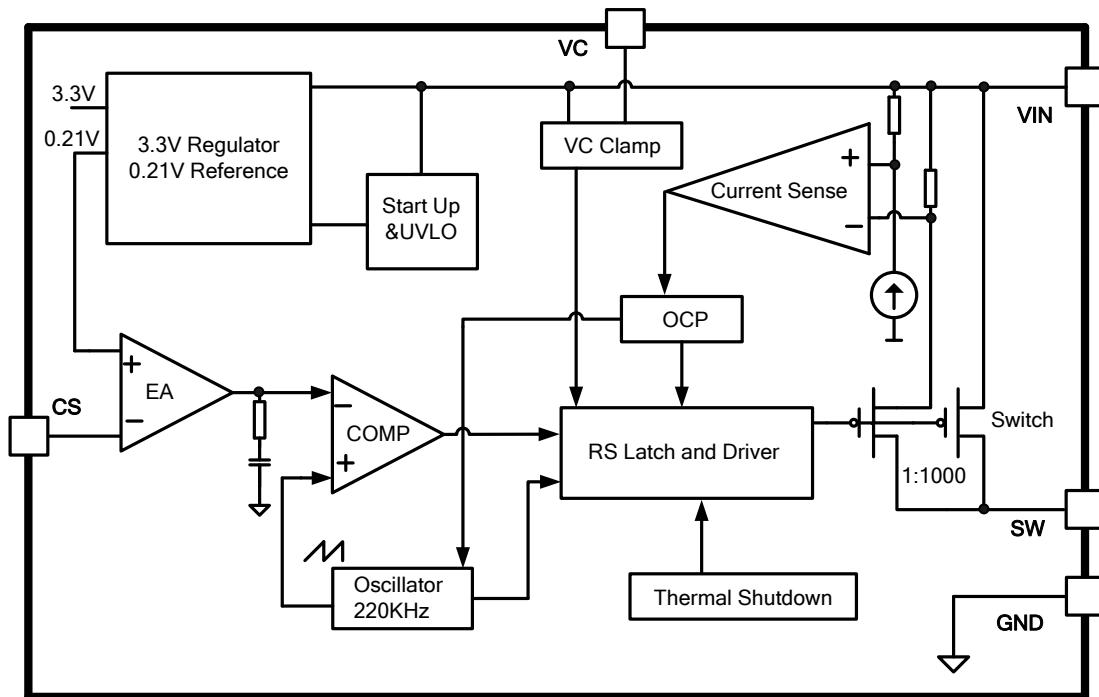

Figure3. Function Block Diagram of XL3001

Typical Application Circuit

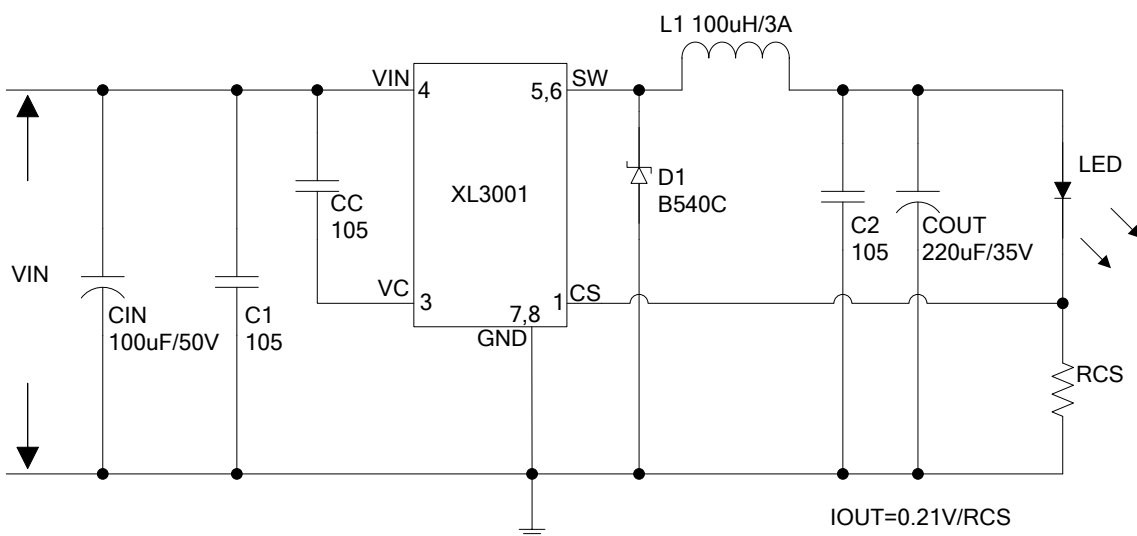

Figure4. XL3001 Typical Application Circuit

3A 220KHz 40V Buck LED Constant Current Driver

XL3001

Ordering Information

Order Information	Marking ID	Package Type	Packing Type Supplied As
XL3001E1	XL3001E1	SOP8-EP	4000 Units on Tape & Reel

XLSEMI Pb-free products, as designated with “E1” suffix in the par number, are RoHS compliant.

Absolute Maximum Ratings (Note1)

Parameter	Symbol	Value	Unit
Input Voltage	V_{in}	-0.3 to 45	V
CS Pin Voltage	V_{CS}	-0.3 to 7	V
Output Switch Pin Voltage	V_{SW}	-0.3 to V_{in}	V
Power Dissipation	P_D	Internally limited	mW
Thermal Resistance (SOP8-EP) (Junction to Ambient, No Heatsink, Free Air)	R_{JA}	60	°C/W
Maximum Junction Temperature	T_J	-40 to 150	°C
Operating Junction Temperature	T_J	-40 to 125	°C
Storage Temperature	T_{STG}	-65 to 150	°C
Lead Temperature (Soldering, 10 sec)	T_{LEAD}	260	°C
ESD (HBM)		>2000	V

Note1: Stresses greater than those listed under Maximum Ratings may cause permanent damage to the device. This is a stress rating only and functional operation of the device at these or any other conditions above those indicated in the operation is not implied. Exposure to absolute maximum rating conditions for extended periods may affect reliability.

3A 220KHz 40V Buck LED Constant Current Driver

XL3001

XL3001 Electrical Characteristics

T_a = 25°C; unless otherwise specified.

Symbol	Parameter	Test Condition	Min.	Typ.	Max.	Unit
System parameters test circuit figure4						
VCS	Current Sense Voltage	V _{in} = 8V to 40V, V _{out} =6.4V I _{load} =0.1A to 2A	203.7	210	216.3	mV
η	Efficiency	V _{in} =12V, V _{out} =10V, I _{out} =0.3A	-	95	-	%
η	Efficiency	V _{in} =24V, V _{out} =16V, I _{out} =0.6A	-	96	-	%
η	Efficiency	V _{in} =36V, V _{out} =20V, I _{out} =0.6A	-	95	-	%

Electrical Characteristics (DC Parameters)

V_{in} = 12V, GND=0V, V_{in} & GND parallel connect a 100uf/50V capacitor; I_{out}=500mA, T_a = 25°C; the others floating unless otherwise specified.

Parameters	Symbol	Test Condition	Min.	Typ.	Max.	Unit
Input operation voltage	V _{in}		8		40	V
VIN UVLO	V _{in_uvlo}			5		V
Quiescent Supply Current	I _q	V _{CS} =2V		2.1	5	mA
Oscillator Frequency	F _{osc}		176	220	264	KHz
Switch Current Limit	I _L	V _{CS} =0V		3.5		A
Max. Duty Cycle	D _{MAX}	V _{CS} =0V		100		%
Output Power PMOS	R _{dson}	V _{CS} =0V, V _{in} =12V, I _{SW} =3A		75	100	mohm

Typical System Application (Recommend output voltage safe work range)

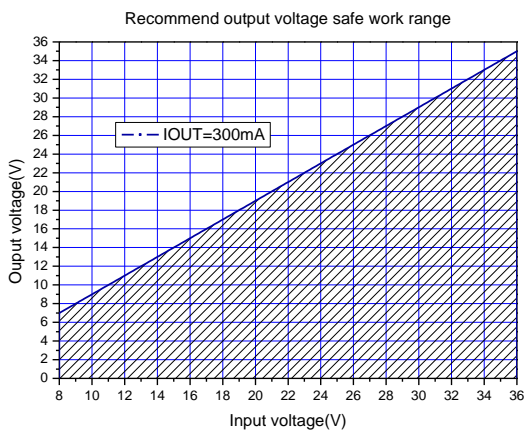

Figure5.Max output voltage(IOUT=300mA)

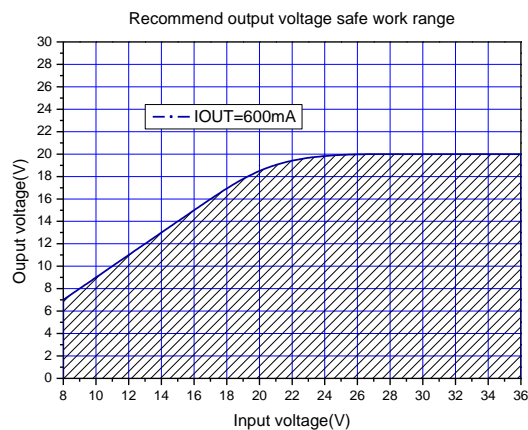

Figure6.Max output voltage(IOUT=600mA)

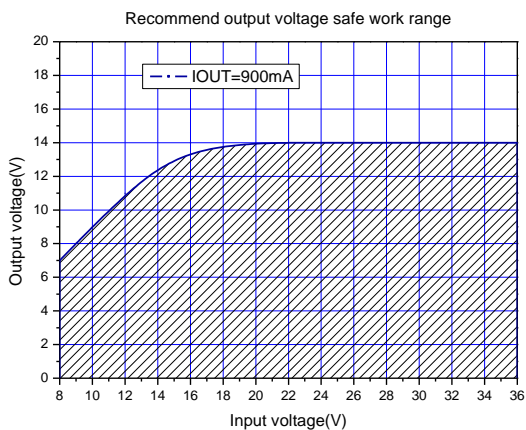

Figure7.Max output voltage(IOUT=900mA)

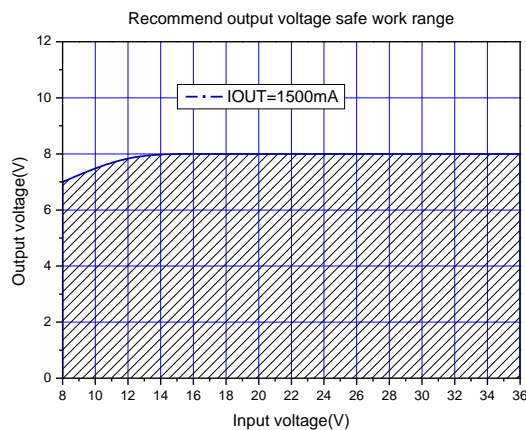

Figure8.Max output voltage(IOUT=1500mA)

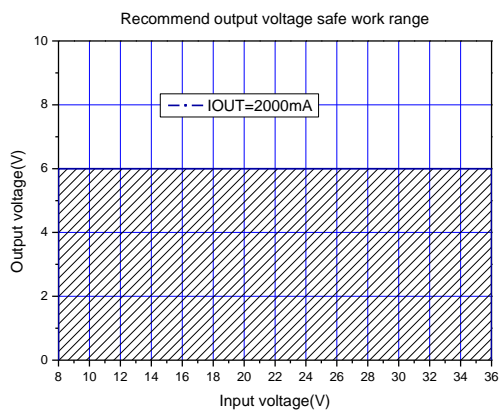

Figure9.Max output voltage(IOUT=2000mA)

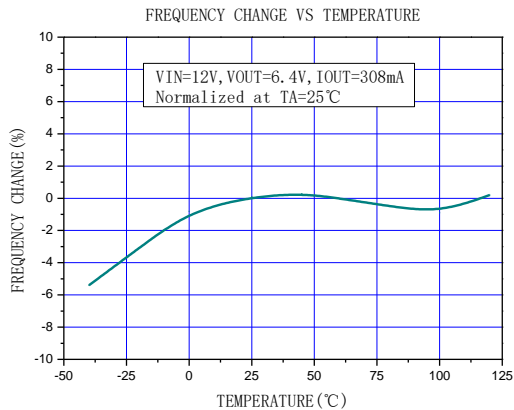

Figure10. Frequency change Curve

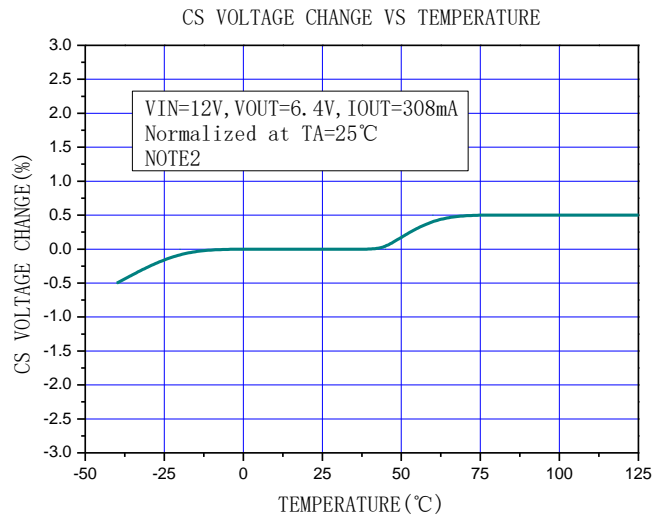

Figure11. CS Voltage change Curve

Note2: Internal temperature compensation circuitry is provided to compensation the PCB and external line loss in system application. When the junction temperature or the output power rise, the CS voltage will be compensated. This function is provided to compensation the PCB and external line loss in system application.

Typical System Application (VIN=8V~40V, IOU=308mA)

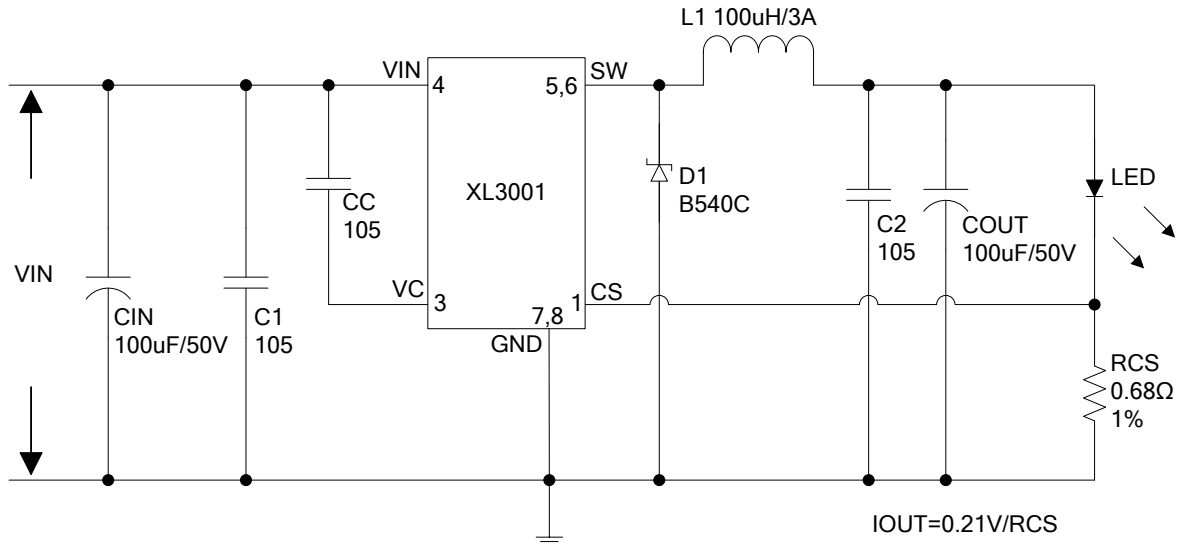

Figure12. XL3001 System Parameters Test Circuit (VIN=8V~40V, IOU=308mA)

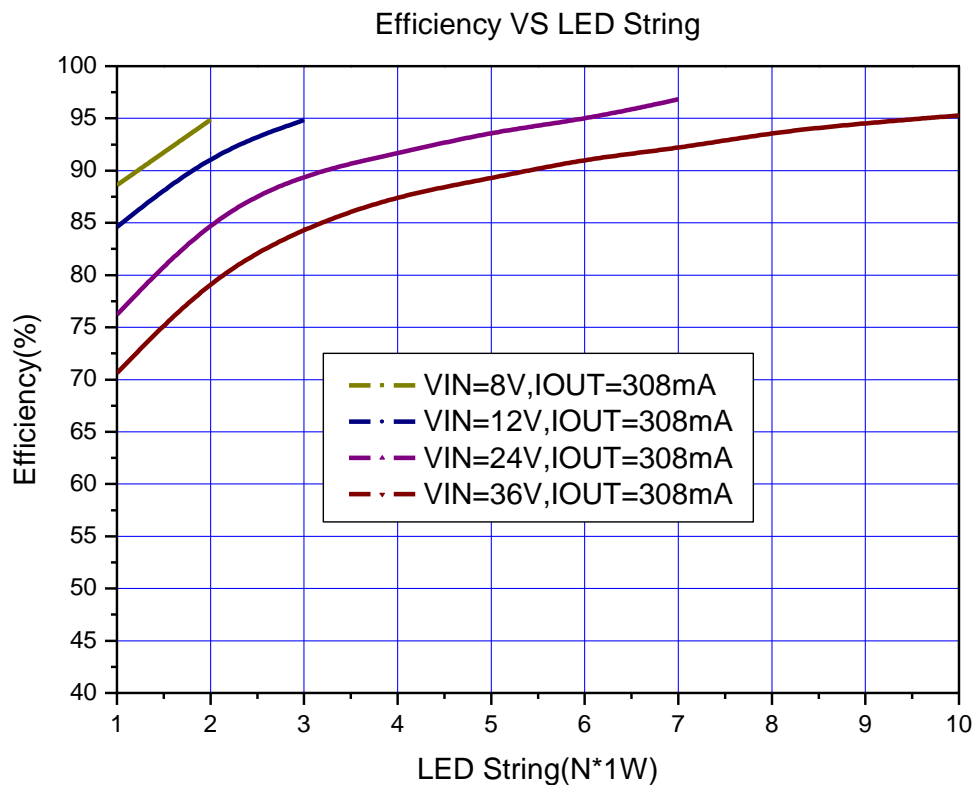

Figure13. XL3001 System Efficiency Curve

Typical System Application (VIN=8V~40V, IOU=615mA)

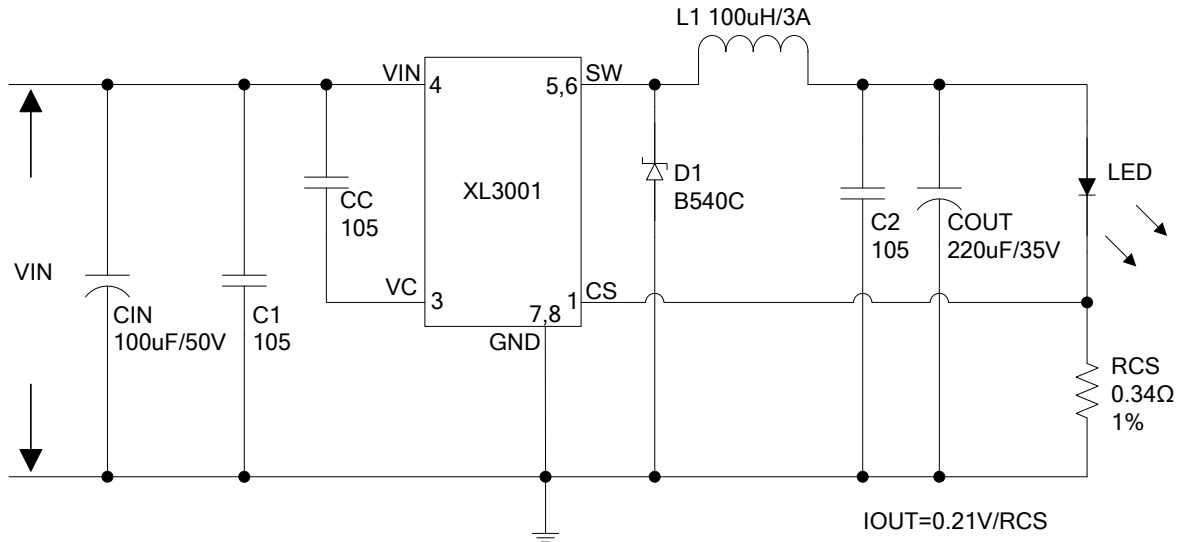

Figure14. XL3001 System Parameters Test Circuit (VIN=8V~40V, IOU=615mA)

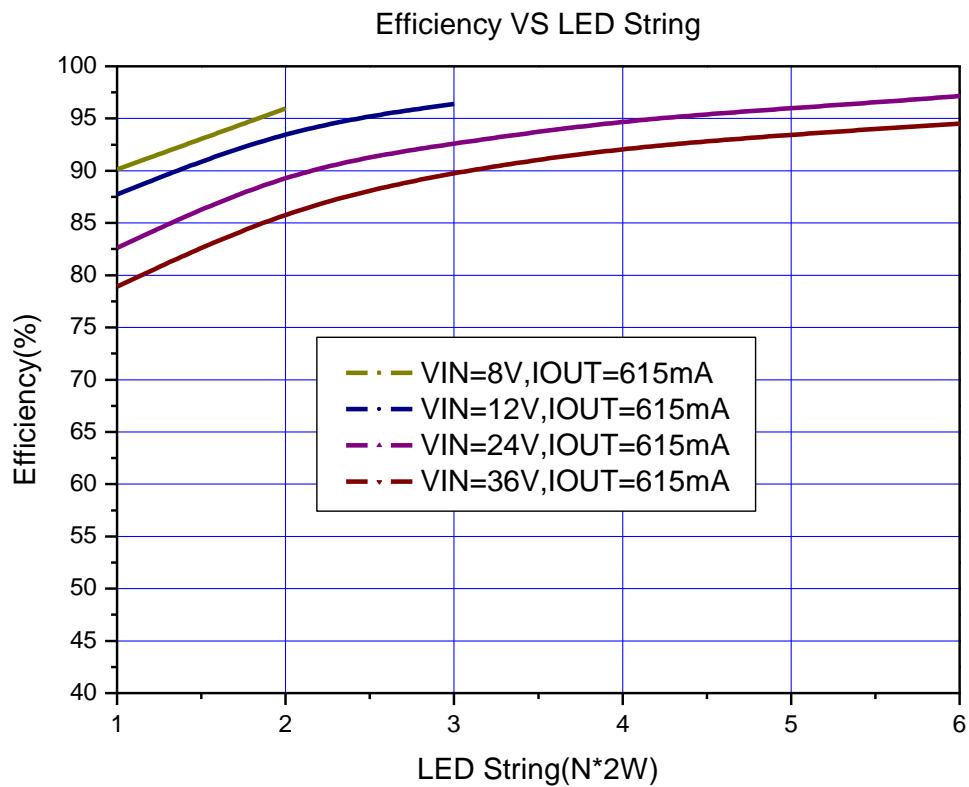

Figure15. XL3001 System Efficiency Curve

Typical System Application (VIN=8V~40V, IOU=925mA)

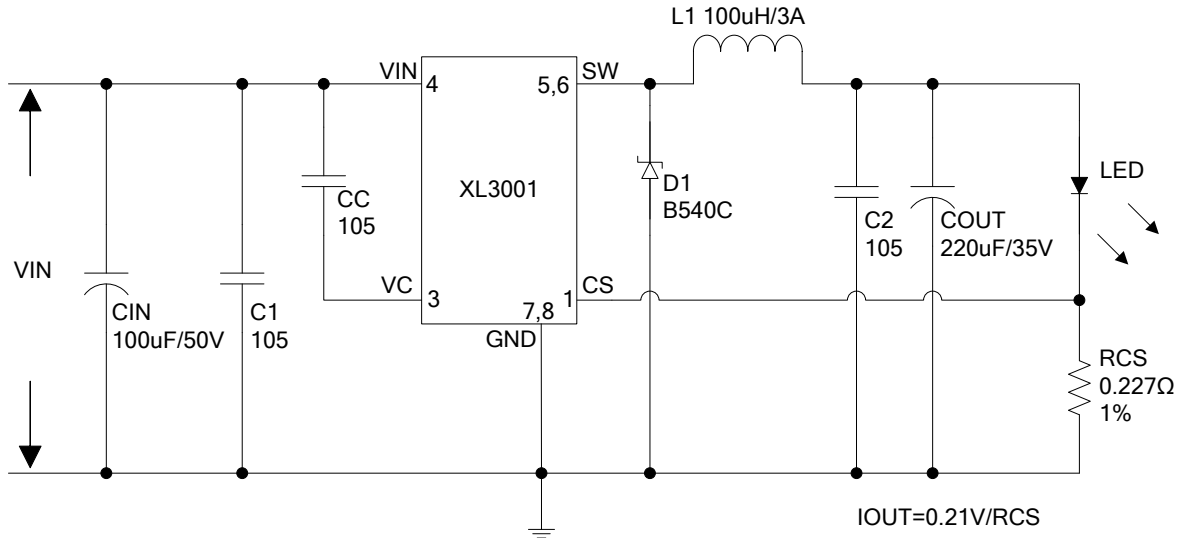

Figure16. XL3001 System Parameters Test Circuit (VIN=8V~40V, IOU=925mA)

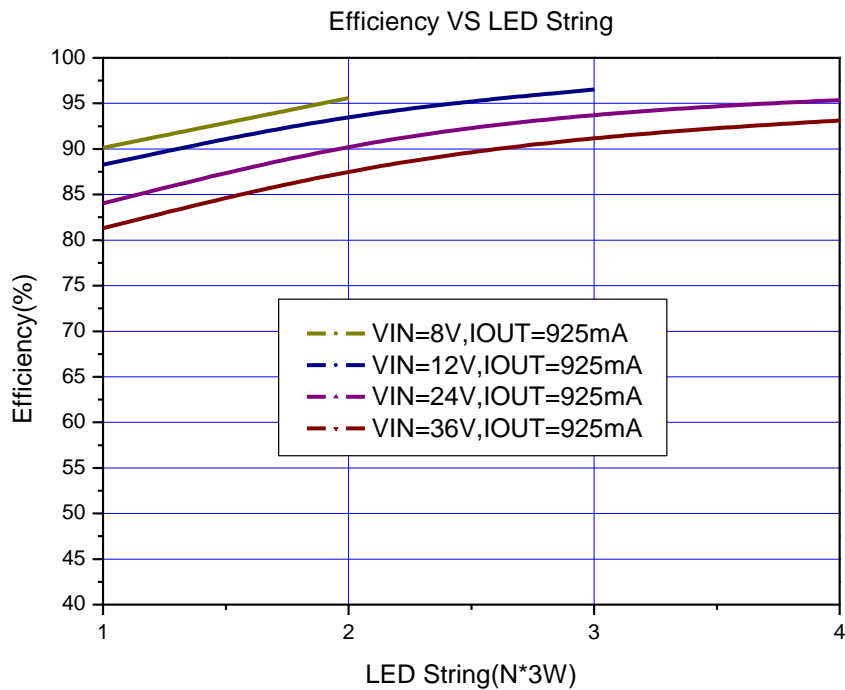

Figure17. XL3001 System Efficiency Curve

Typical System Application (PWM DIMMING)

PWM dimming function can be used in typical system application with external components. Changing the duty cycle of PWM signal can get different LED current. The PWM signal voltage is 3.3V or 5V.

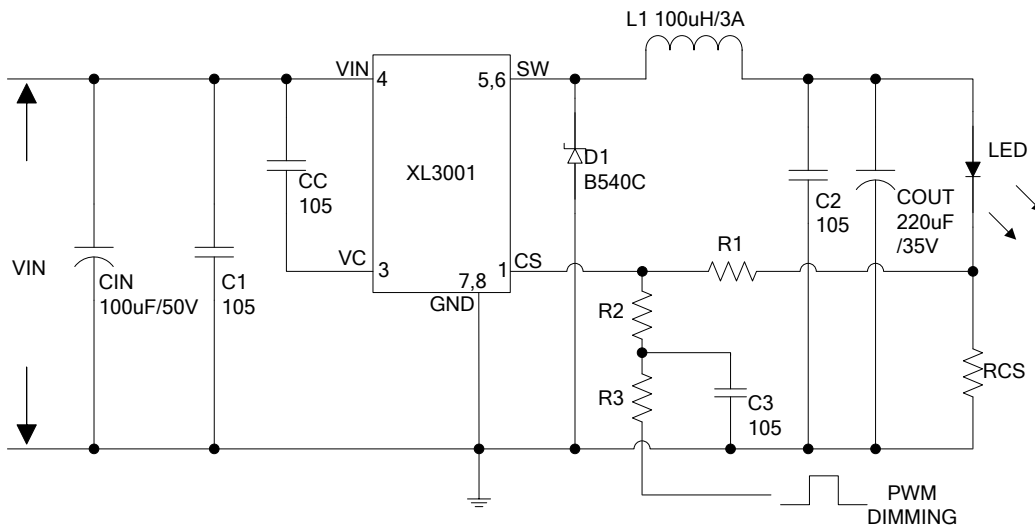

Figure18. XL3001 System Parameters Test Circuit (PWM DIMMING)

Typical System Application (LED Open Protection)

LED Open Protection function can be used in typical system application with external components. The output voltage can be limited in a suitable value by choosing different zener diode when the output LED open. the zener diode voltage choosed by output led voltage's 1.3 times.

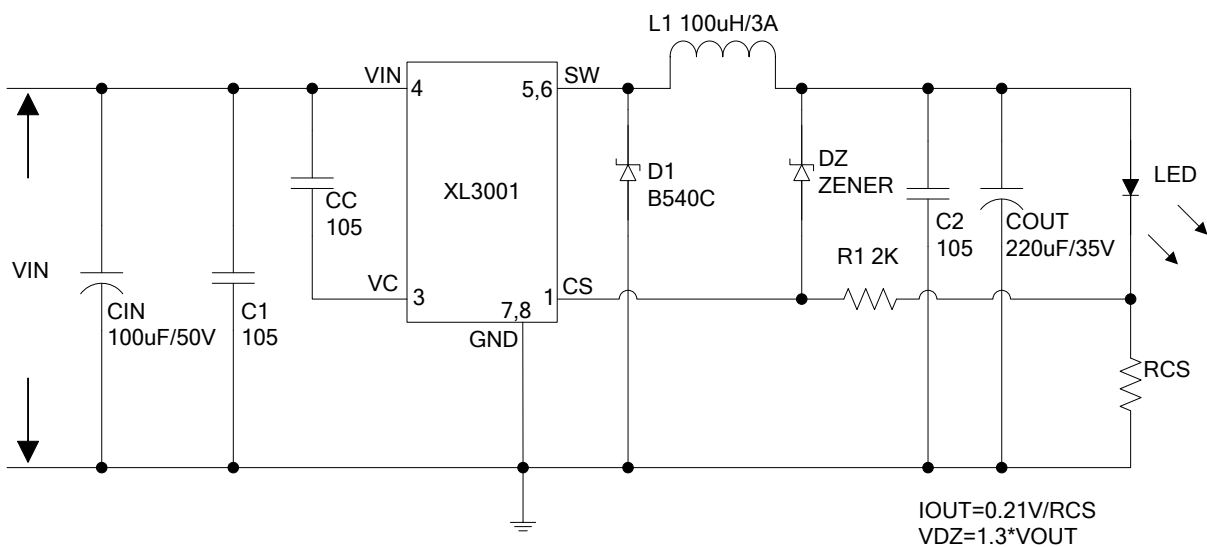
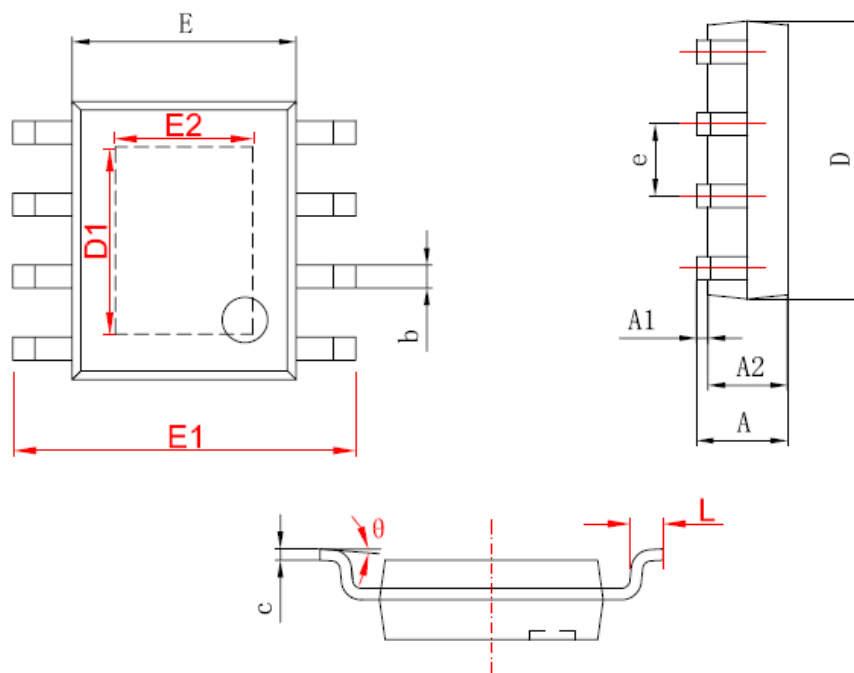

Figure19. XL3001 System Parameters Test Circuit (LED Open Protection)

Package Information

SOP8-EP



Symbol	Dimensions In Millimeters		Dimensions In Inches	
	Min.	Max.	Min.	Max.
A	1.350	1.750	0.053	0.069
A1	0.000	0.150	0.000	0.006
A2	1.250	1.650	0.049	0.065
b	0.306	0.510	0.012	0.020
c	0.170	0.250	0.007	0.010
D	4.700	5.100	0.185	0.201
D1	2.650	3.467	0.104	0.136
E	3.800	4.000	0.150	0.157
E1	5.800	6.200	0.228	0.244
E2	1.910	2.534	0.075	0.100
e	1.140	1.400	0.045	0.055
L	0.450	0.800	0.018	0.031
θ	0°	8°	0°	8°

3A 220KHz 40V Buck LED Constant Current Driver	XL3001
--	--------

Important Notice

XLSEMI reserve the right to make modifications, enhancements, improvements, corrections or other changes without notice at any time. XLSEMI does not assume any liability arising out of the application or use of any product described herein; neither does it convey any license under its patent rights, nor the rights of others. XLSEMI assumes no liability for applications assistance or the design of Buyers' products. Buyers are responsible for their products and applications using XLSEMI components. To minimize the risks associated with Buyers' products and applications, Buyers should provide adequate design and operating safeguards. XLSEMI warrants performance of its products to the specifications applicable at the time of sale, in accordance with the warranty in XLSEMI's terms and conditions of sale of semiconductor products. Testing and other quality control techniques are used to the extent XLSEMI deems necessary to support this warranty. Except where mandated by applicable law, testing of all parameters of each component is not necessarily performed.

For the latest product information, go to www.xlsemi.com.