

1.5A 220KHz 65V Buck LED Constant Current Driver

XL3007

Features

- Operation Voltage: 8V~60V
- 0.21V Constant Current Sense Voltage
- Directly drive 1~12 Series 1W LED
- Current Sense Voltage Accuracy $\pm 3\%$
- Fixed 220KHz Switching Frequency
- 1.5A Constant Output Current Capability
- Internal Optimize Power MOSFET
- High efficiency up to 95%
- Max. Output power up to 12W
- Maximum Duty Cycle 100%
- Excellent line and load regulation
- Built in thermal shutdown function
- Built in current limit protection function
- Temperature Grade 1: -40°C to 125°C
Ambient Operating Temperature Range
- Device HBM ESD Classification Level
Class3A
- Available in SOP8-EP package

General Description

The XL3007 is a 220KHz fixed frequency PWM buck LED constant current driver, capable of driving a 1.5A load with high efficiency, low ripple and excellent line and load regulation. XL3007 supports wide input operating voltage range of 8V ~ 60V and a maximum duty cycle of 100% output. A built-in loop compensation module reduces components in the system, lowering power system cost and reducing printed circuit board space.

The XL3007 has built-in thermal shutdown, current limit protection and so on.

Applications

- Buck constant current driver
- LED backlight driver
- General purpose LED lighting

Typical application schematic

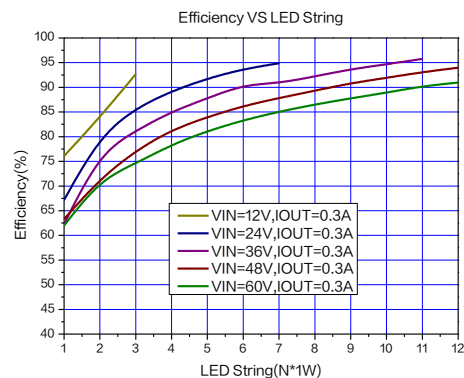
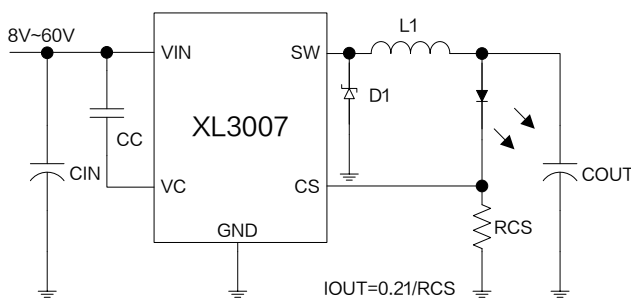

Figure1. XL3007 Typical application schematic and efficiency curve

Pin Configurations

CS	1	8	GND
NC	2	7	GND
	XL3007		
VC	3	6	SW
VIN	4	5	SW

The back exposed PAD is SW

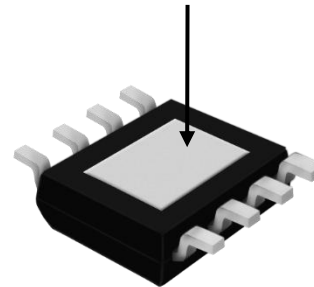

Figure2. Pin Configuration of XL3007

Table 1 Pin Description

Pin Number	Pin Name	Description
1	CS	Output constant current sense Pin (CS). The CS reference voltage is 0.21V.
2	NC	Not connected.
3	VC	Internal Voltage Regulator Bypass Capacity. In typical system application, The VC pin connect a 1uF capacitor to VIN.
4	VIN	Supply Voltage Input Pin. XL3007 operates from 8V to 60V DC voltage. Bypass Vin to GND with a suitably large capacitor to eliminate noise on the input.
5,6	SW	Power Switch Output Pin (SW). Output is the switch node that supplies power to the output.
7,8	GND	Ground Pin.

Ordering Information

Order Information	Marking ID	Package Type	Eco Plan	Packing Type Supplied As
XL3007	XL3007	SOP8-EP	RoHS & HF	4000 Units on Reel

Function Block

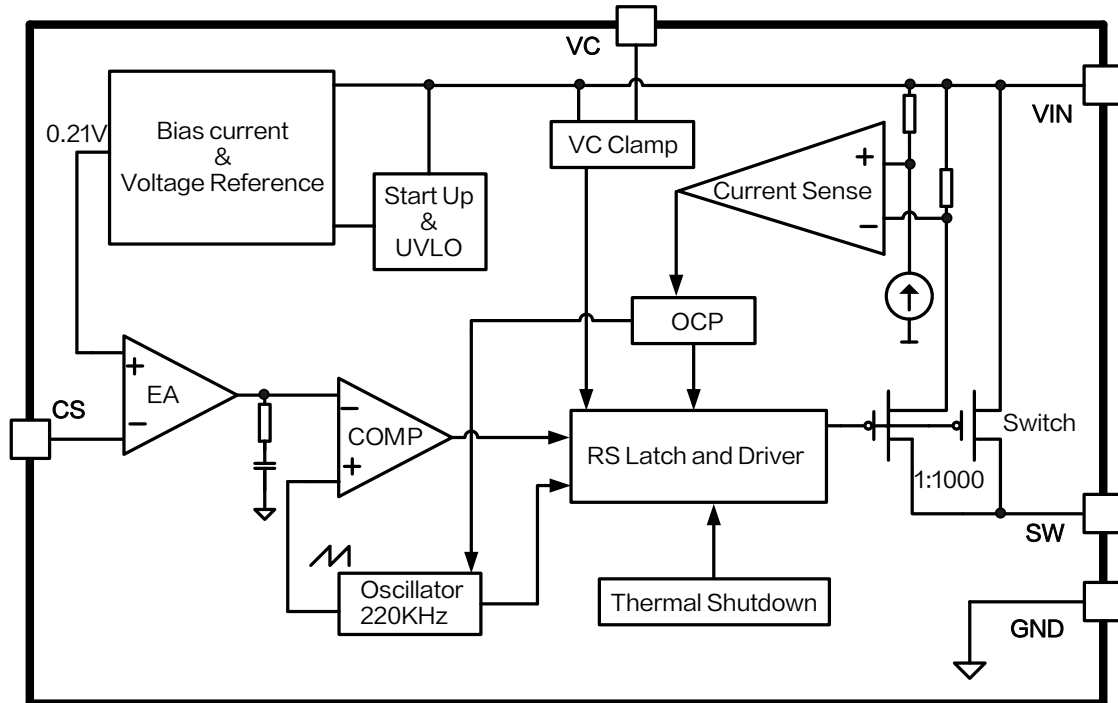

Figure3. Function Block Diagram of XL3007

Absolute Maximum Ratings (Note1)

Parameter	Symbol	Value	Unit
Input Voltage	V_{IN}	-0.3~65	V
VC Pin Voltage	V_C	-0.3~ V_{IN}	V
Output Switch Pin Voltage	V_{SW}	-0.3~ V_{IN}	V
Current Sense Pin Voltage	V_{CS}	-0.3~7	V
Power Dissipation	P_D	Internally limited	mW
Thermal Resistance (SOP8-EP) (Junction to Ambient, No Heatsink, Free Air)	R_{JA}	60	$^{\circ}C/W$
Operating Junction Temperature	T_J	-40~150	$^{\circ}C$
Storage Temperature	T_{STG}	-65~150	$^{\circ}C$
Lead Temperature (Soldering, 10 sec)	T_{LEAD}	260	$^{\circ}C$
ESD (HBM)		>4000	V

Note1: Stresses greater than those listed under Maximum Ratings may cause permanent damage to the device. This is a stress rating only and functional operation of the device at these or any other conditions above those indicated in the operation is not implied. Exposure to absolute maximum rating conditions for extended periods may affect reliability.

1.5A 220KHz 65V Buck LED Constant Current Driver

XL3007

XL3007 Electrical Characteristics

$T_A = 25^\circ\text{C}$; system parameters test circuit figure4, unless otherwise specified.

Symbol	Parameter	Test Condition	Min.	Typ.	Max.	Unit
V_{CS}	Current Sense Voltage	$V_{IN} = 12\text{V}, V_{OUT} = 3.3\text{V}$ $I_{OUT} = 0.3\text{A}$	203.7	210.0	216.3	mV
η	Efficiency	$V_{IN} = 12\text{V}, V_{OUT} = 9.9\text{V}$ $I_{OUT} = 0.3\text{A}$	-	92.7	-	%
η	Efficiency	$V_{IN} = 24\text{V}, V_{OUT} = 19.8\text{V}$ $I_{OUT} = 0.6\text{A}$	-	95.4	-	%

Electrical Characteristics (DC Parameters)

$T_A = 25^\circ\text{C}, V_{IN} = 12\text{V}, I_{OUT} = 0.3\text{A}$; system parameters test circuit figure4, unless otherwise specified.

Parameters	Symbol	Test Condition	Min.	Typ.	Max.	Unit
Input operation voltage	V_{IN}		8		60	V
VIN UVLO	V_{IN_UVLO}			5		V
Quiescent Supply Current	I_Q	$V_{CS} = 2\text{V}$		1.8	5	mA
Oscillator Frequency	F_{OSC}		198	220	242	KHz
Switch Current Limit	I_L	$V_{CS} = 0\text{V}$		1.7		A
MOS On-resistance	$R_{DS(ON)}$	$V_{CS} = 0\text{V}, I_{SW} = 0.5\text{A}$		270		m Ω
Thermal Shutdown Temperature	T_{SD}			170		$^\circ\text{C}$
Thermal Shutdown Hysteresis	T_D			20		$^\circ\text{C}$
Max. Duty Cycle	D_{MAX}	$V_{CS} = 0\text{V}$		100		%

Typical System Application Schematic ($I_{OUT}=0.3A$)

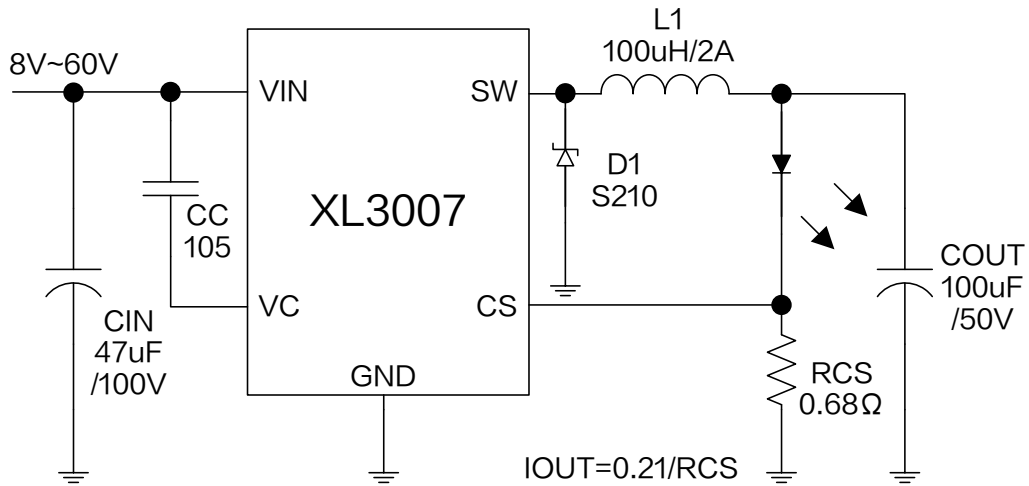

Figure4. XL3007 System Parameters Test Circuit ($V_{IN}=8V\sim 60V, I_{OUT}=0.3A$)

Typical System Application Transfer Efficiency

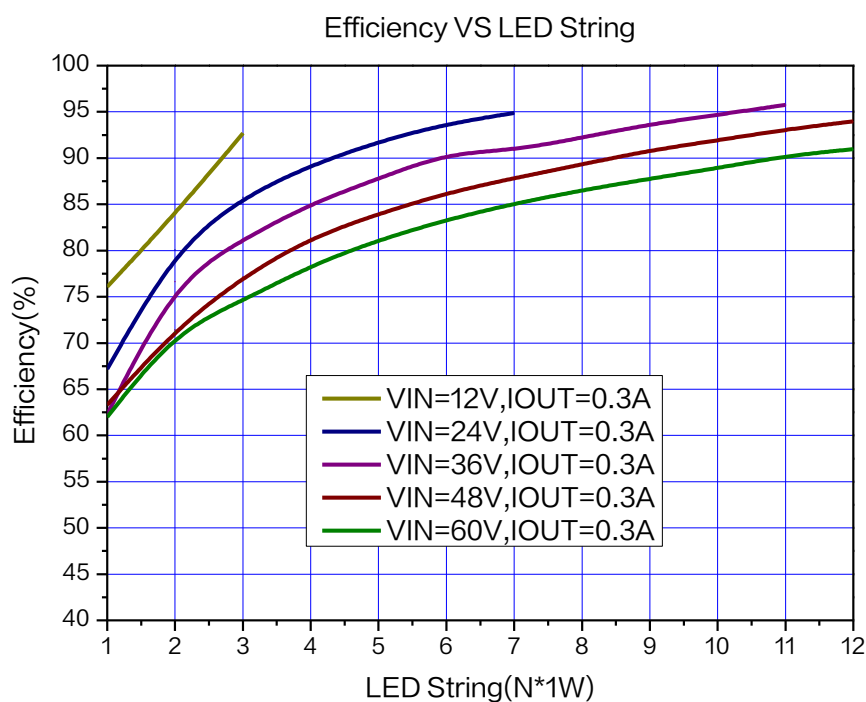

Figure5. XL3007 System Efficiency Curve ($I_{OUT}=0.3A$)

Typical System Application Schematic ($I_{OUT}=0.6A$)

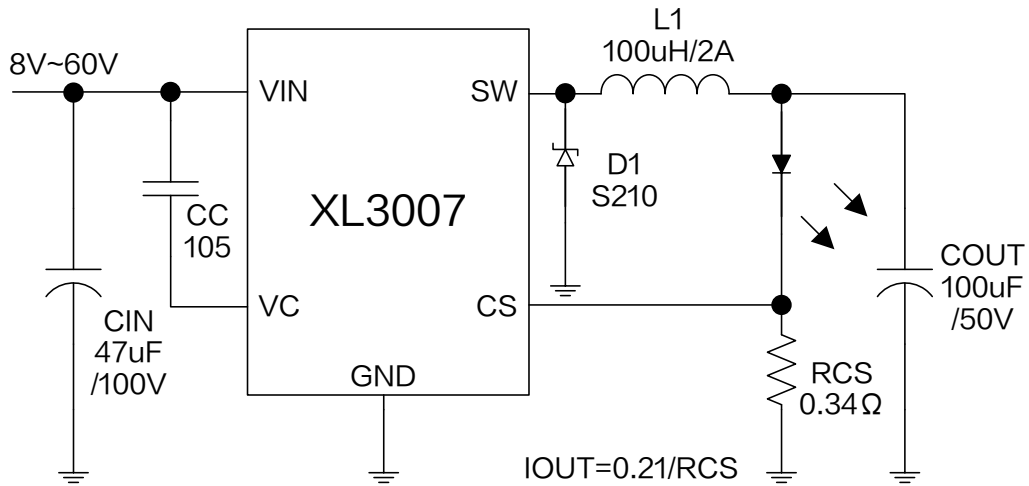

Figure6. XL3007 System Parameters Test Circuit ($V_{IN}=8V\sim60V, I_{OUT}=0.6A$)

Typical System Application Transfer Efficiency

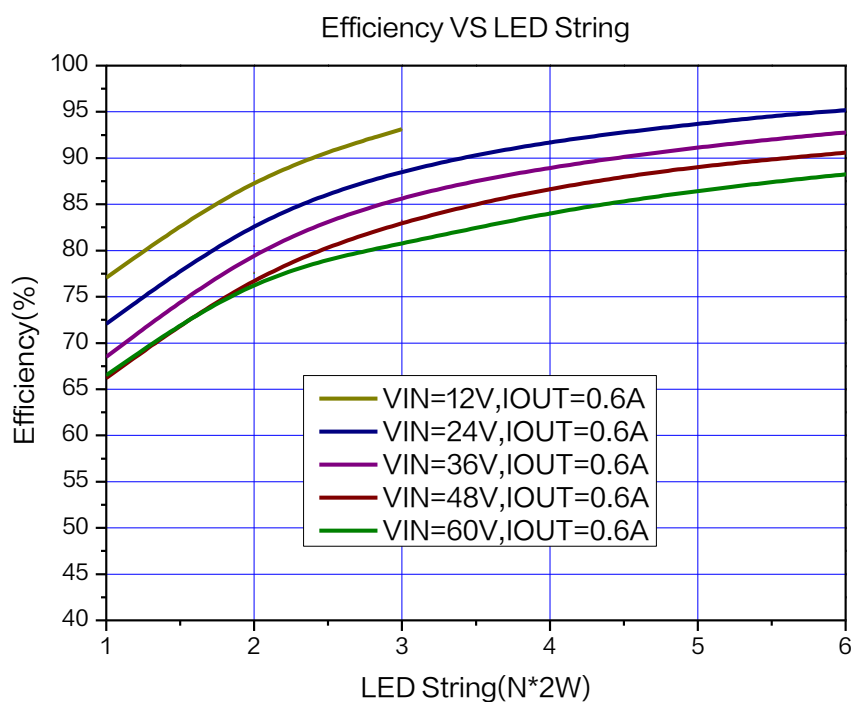

Figure7. XL3007 System Efficiency Curve ($I_{OUT}=0.6A$)

Typical System Application Schematic ($I_{OUT}=0.9A$)

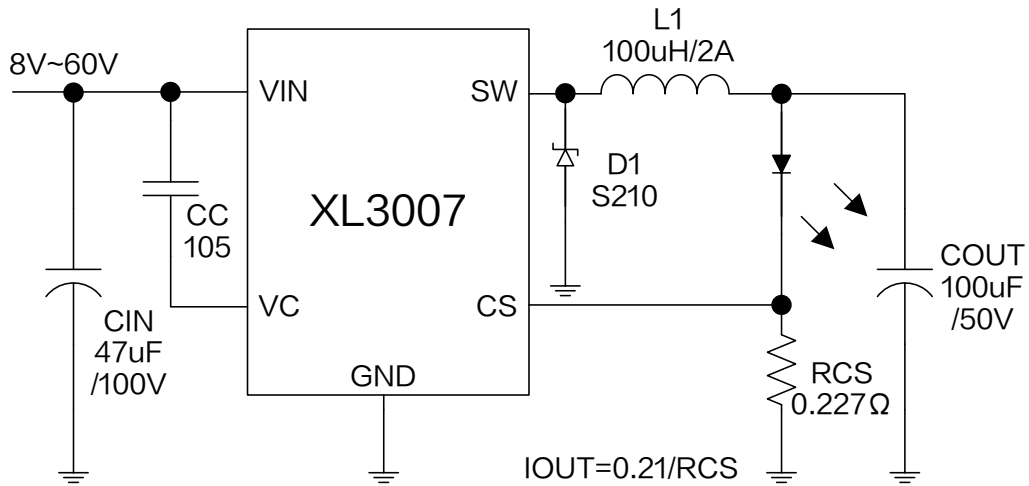

Figure8. XL3007 System Parameters Test Circuit ($V_{IN}=8V\sim60V, I_{OUT}=0.9A$)

Typical System Application Transfer Efficiency

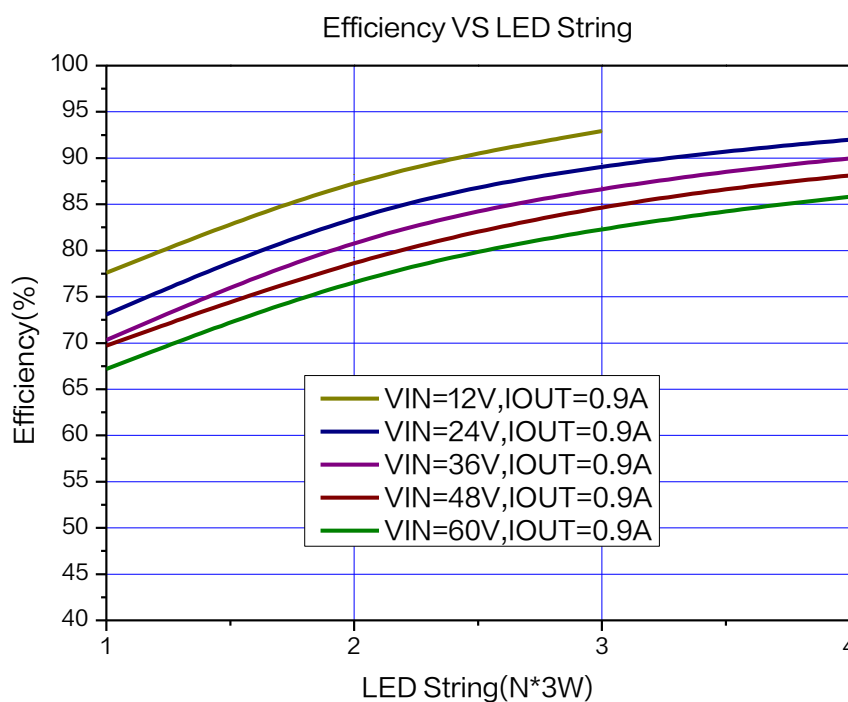

Figure9. XL3007 System Efficiency Curve ($I_{OUT}=0.9A$)

Typical System Application Schematic ($I_{OUT}=1.2A$)

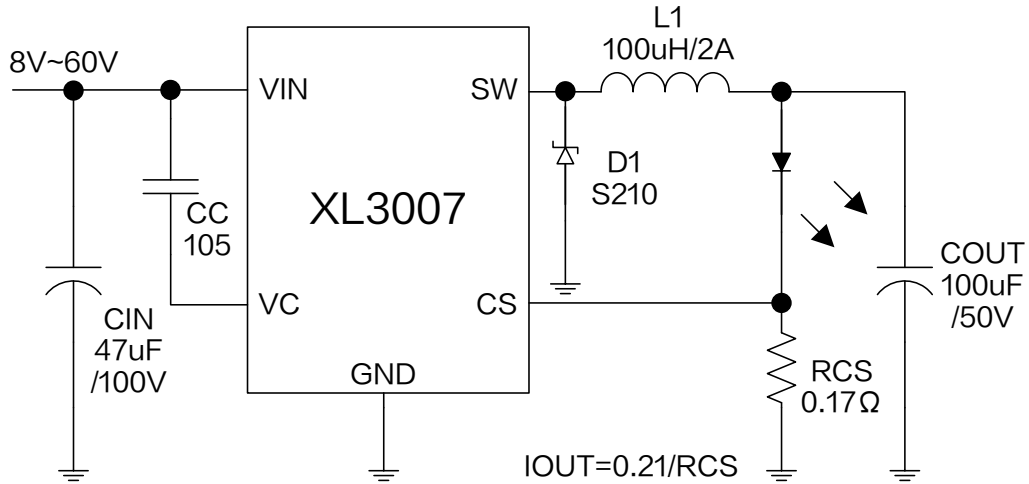

Figure10. XL3007 System Parameters Test Circuit ($V_{IN}=8V\sim60V, I_{OUT}=1.2A$)

Typical System Application Transfer Efficiency

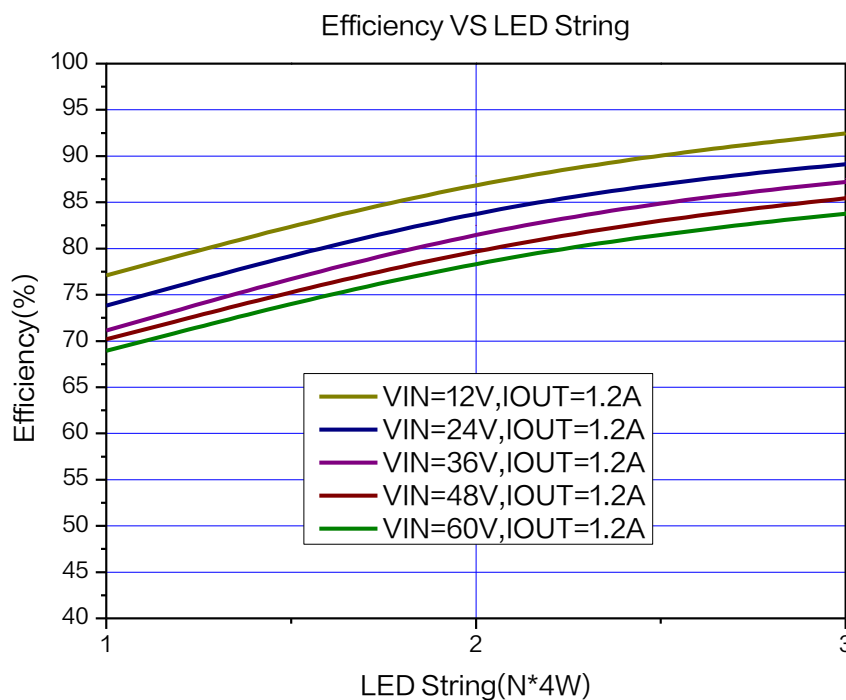

Figure11. XL3007 System Efficiency Curve ($I_{OUT}=1.2A$)

Typical System Application (PWM DIMMING)

PWM dimming function can be used in typical system application with external components. Changing the duty cycle of PWM signal can get different LED current. The PWM signal voltage is 5V.

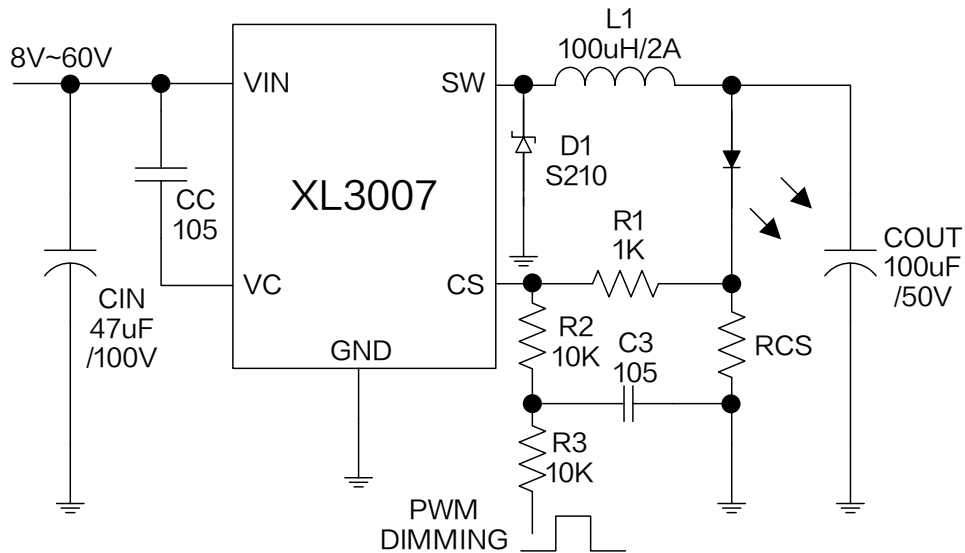

Figure12. XL3007 System Parameters Test Circuit (PWM DIMMING)

Typical System Application (LED Open Protection)

LED Open Protection function can be used in typical system application with external components. The output voltage can be limited in a suitable value by choosing different zener diode when the output LED open. The zener diode voltage chosen by output led voltage's 1.3 times.

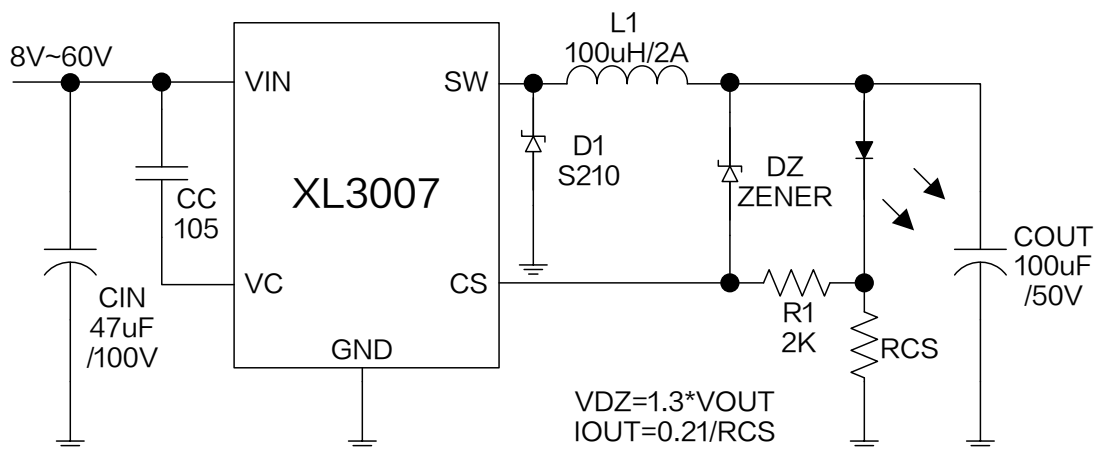

Figure13. XL3007 System Parameters Test Circuit (LED Open Protection)

Typical Characteristics (LED forward voltage V_F is 3.3V at $I_F=0.3A$, unless otherwise noted.)

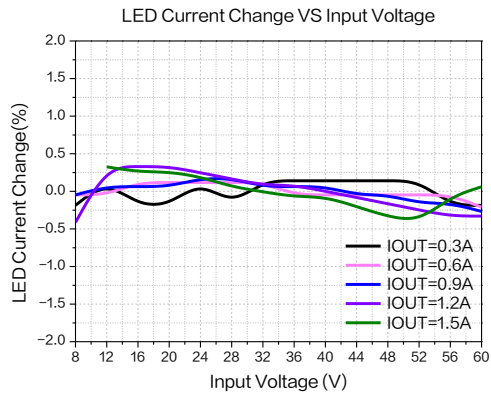

Figure14.Line Regulation

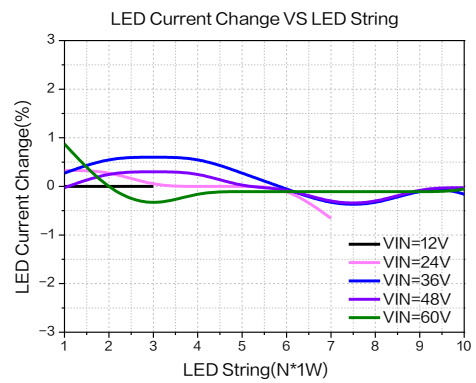

Figure15.Load Regulation

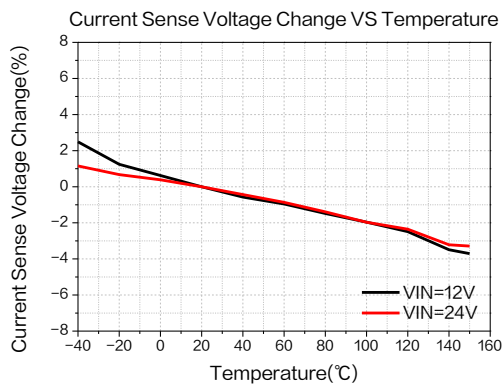

Figure16.Current Sense Voltage Regulation

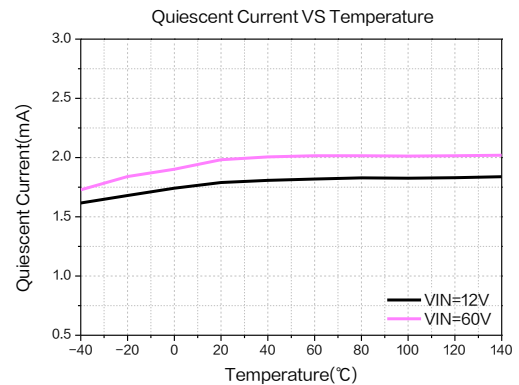

Figure17.Quiescent Current

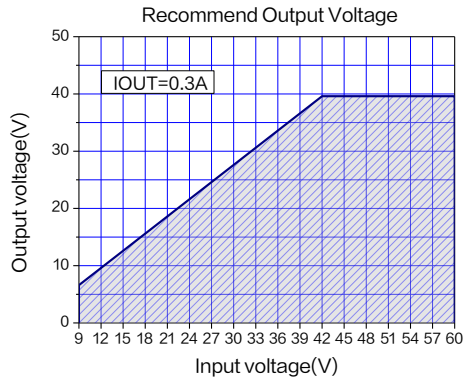

Figure18.Max Output Voltage
($I_{OUT}=0.3A$, $T_A=25^\circ C$)

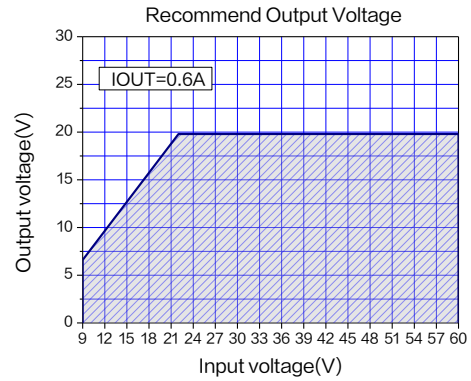

Figure19.Max Output Voltage
($I_{OUT}=0.6A$, $T_A=25^\circ C$)

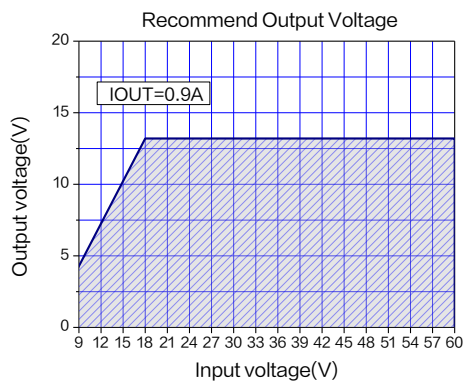

Figure20.Max Output Voltage
($I_{OUT}=0.9A$, $T_A=25^\circ C$)

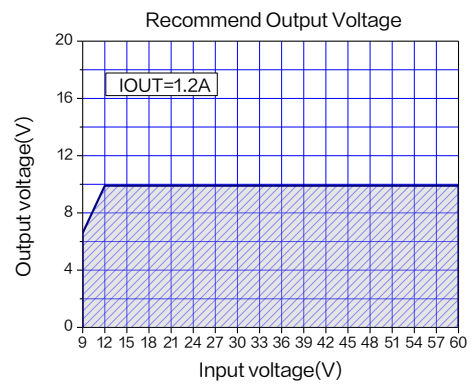

Figure21.Max Output Voltage
($I_{OUT}=1.2A$, $T_A=25^\circ C$)

1.5A 220KHz 65V Buck LED Constant Current Driver

XL3007

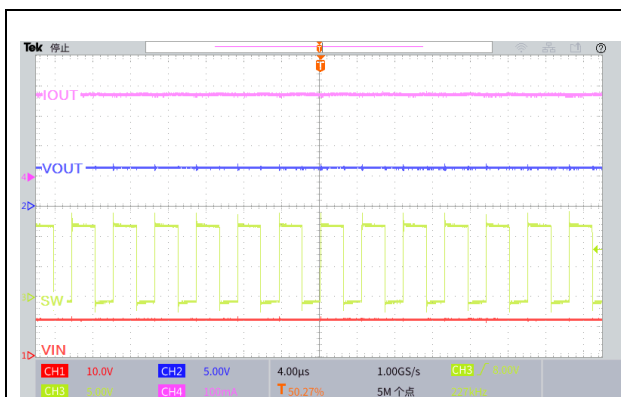

Figure22. LED Current Ripple
($V_{IN}=12V$, $V_{OUT}=6.6V$, $I_{OUT}=0.3A$)

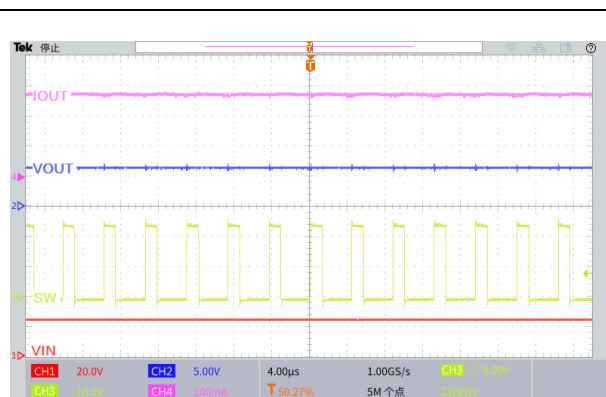

Figure23. LED Current Ripple
($V_{IN}=24V$, $V_{OUT}=6.6V$, $I_{OUT}=0.3A$)

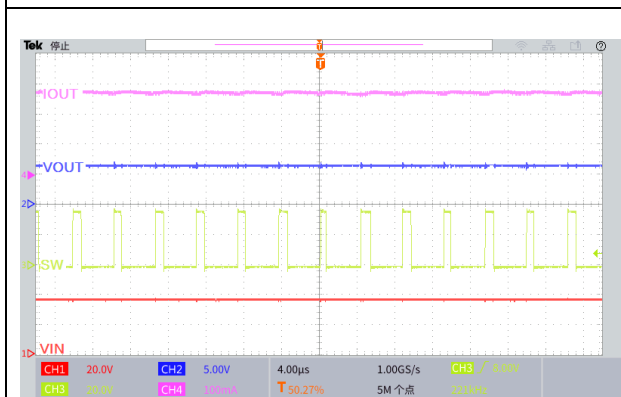

Figure24. LED Current Ripple
($V_{IN}=36V$, $V_{OUT}=6.6V$, $I_{OUT}=0.3A$)

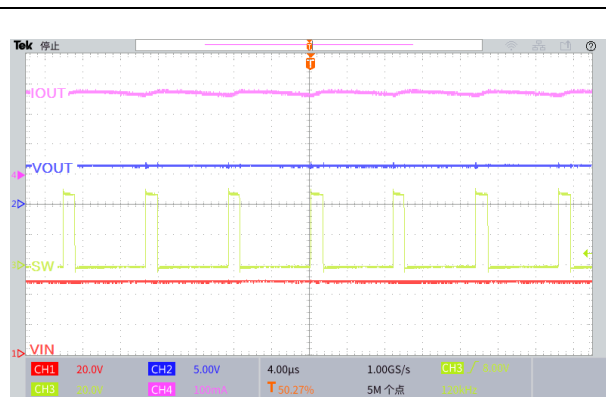
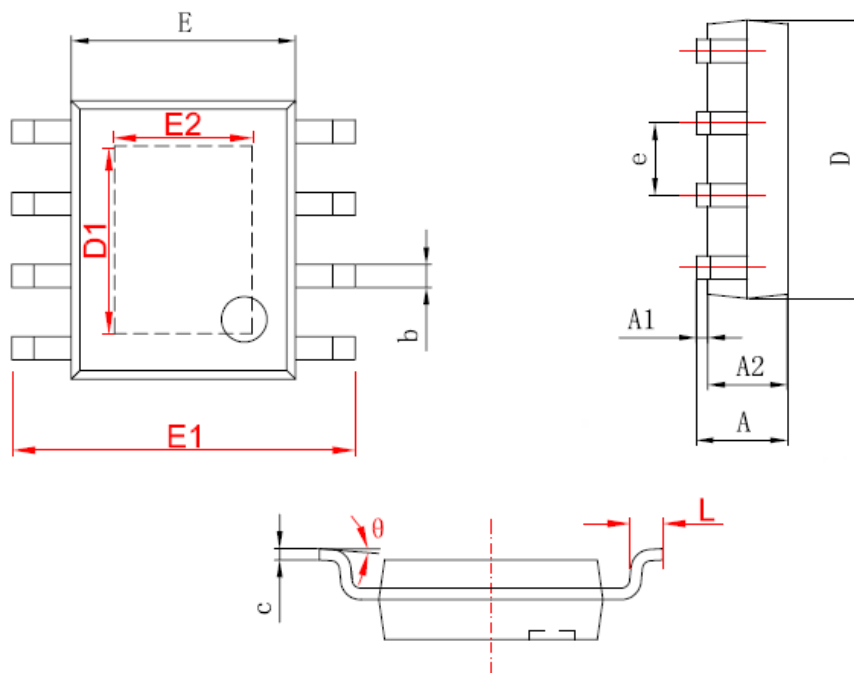

Figure25. LED Current Ripple
($V_{IN}=48V$, $V_{OUT}=6.6V$, $I_{OUT}=0.3A$)

Package Information

SOP8-EP



Symbol	Dimensions In Millimeters		Dimensions In Inches	
	Min.	Max.	Min.	Max.
A	1.350	1.750	0.053	0.069
A1	0.000	0.150	0.000	0.006
A2	1.250	1.650	0.049	0.065
b	0.306	0.510	0.012	0.020
c	0.170	0.250	0.007	0.010
D	4.700	5.100	0.185	0.201
D1	2.650	3.467	0.104	0.136
E	3.800	4.000	0.150	0.157
E1	5.800	6.200	0.228	0.244
E2	1.910	2.534	0.075	0.100
e	1.140	1.400	0.045	0.055
L	0.450	0.800	0.018	0.031
θ	0°	8°	0°	8°

1.5A 220KHz 65V Buck LED Constant Current Driver	XL3007
--	--------

Important Notice

XLSEMI reserve the right to make modifications, enhancements, improvements, corrections or other changes without notice at any time. XLSEMI does not assume any liability arising out of the application or use of any product described herein; neither does it convey any license under its patent rights, nor the rights of others. XLSEMI assumes no liability for applications assistance or the design of Buyers' products. Buyers are responsible for their products and applications using XLSEMI components. To minimize the risks associated with Buyers' products and applications, Buyers should provide adequate design and operating safeguards. XLSEMI warrants performance of its products to the specifications applicable at the time of sale, in accordance with the warranty in XLSEMI's terms and conditions of sale of semiconductor products. Testing and other quality control techniques are used to the extent XLSEMI deems necessary to support this warranty. Except where mandated by applicable law, testing of all parameters of each component is not necessarily performed.

For the latest product information, go to www.xlsemi.com.