

Features

- Operation Voltage: 2.5V~20V
- Output Voltage: 3V~32V
- Shutdown Current: 3uA
- Fixed 1.2MHz Switching Frequency
- 500mA Constant Output Current Capability
- Built in High Frequency Power Transistor
- Built in Schottky Diode
- High Efficiency up to 87%
- Excellent line and load regulation
- EN PIN TTL ON/OFF capability
- Built in Output Overvoltage protection function
- Built in thermal shutdown function
- Device HBM ESD Classification Level Class3A
- Available in SOT23-6 package

General Description

XL6107 is a built in high frequency power transistor and Schottky diode Boost DC/DC converter, fixed 1.2MHz frequency PWM, can support input operating voltage range of 2.5V~20V, built in frequency compensation circuitry allows the use of small external components at a price suitable for lowering the cost of the entire power supply system and reduce the printed circuit board space. The output voltage is adjustable by external divider resistors, and the low feedback voltage of 410mV reduces the power consumption of the external sampling resistors, the EN pin supports TTL ON/OFF, and the built in output overvoltage protection and thermal shutdown protection. Suitable for very low quiescent current and ultra-small size applications.

Applications

- Panel Power Supply
- GPS Receiver
- DSL modem
- Wearable portable electronic devices

Typical application schematic

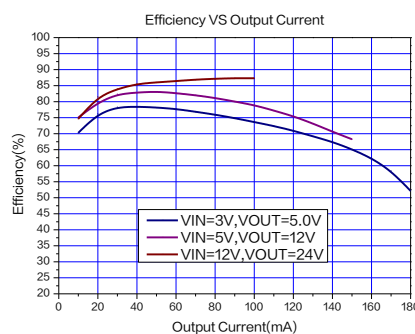
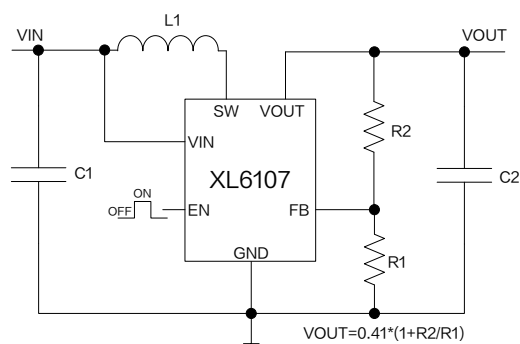

Figure1. XL6107 Typical application schematic and efficiency curve

Pin Configurations

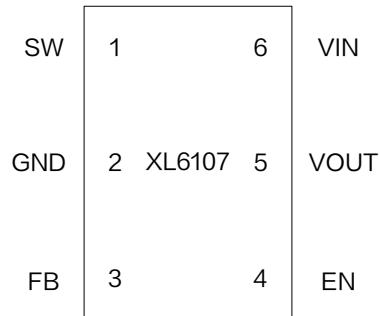

Figure2. Pin Configuration of XL6107

Table 1. Pin Description

Pin Number	Pin Name	Description
1	SW	Power Switch Pin.
2	GND	Ground Pin.
3	FB	Feedback Pin. Through an external resistor divider network, FB senses the output voltage and regulates it. The feedback threshold voltage is 410mV.
4	EN	Enable Pin. Drive EN pin high to turn on the device, drive it low to turn it off. Floating is default high.
5	VOUT	Output Pin.
6	VIN	Supply Voltage Input Pin. XL6107 operates from 2.5V to 20V DC voltage. Bypass Vin to GND with a suitably capacitor to eliminate noise on the input.

Ordering Information

Order Information	Marking ID	Package Type	Eco Plan	Packing Type Supplied As
XL6107	6107	SOT23-6	RoHS & HF	3000 Units on Reel

Function Block

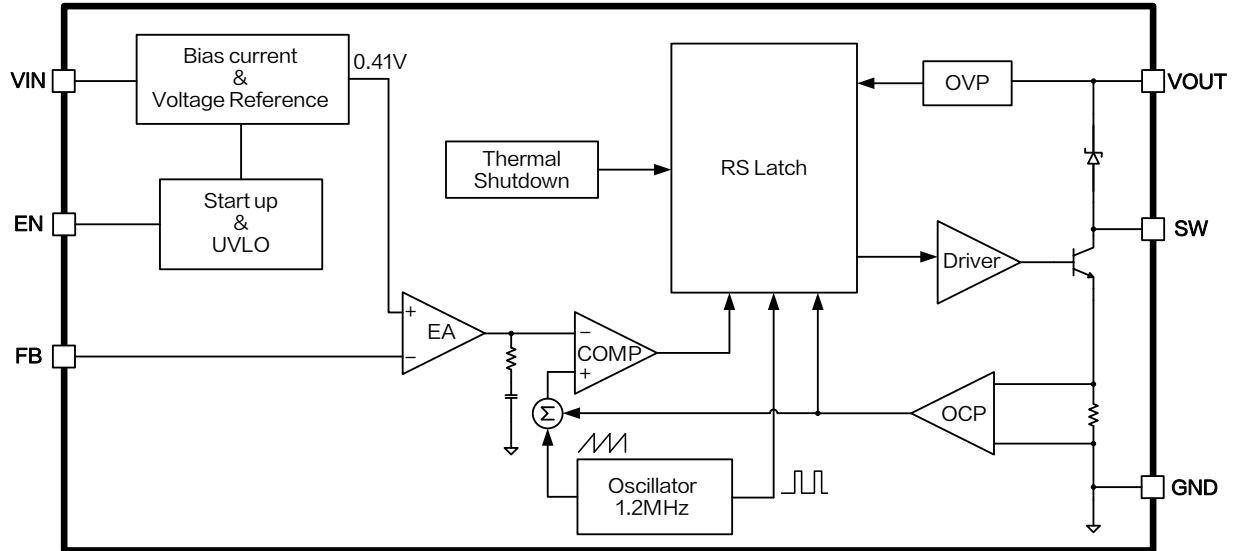

Figure3. Function Block Diagram of XL6107

Absolute Maximum Ratings (Note1)

Parameter	Symbol	Value	Unit
Input Voltage	V_{IN}	-0.3~25	V
EN Pin Voltage	V_{EN}	-0.3~ V_{IN}	V
Feedback Pin Voltage	V_{FB}	-0.3~ V_{IN}	V
Switch Pin Voltage	V_{SW}	-0.3~40	V
VOUT Pin Voltage	V_{OUT}	-0.3~40	V
Power Dissipation	P_D	250	mW
Thermal Resistance (SOT23-6) (Junction to Ambient, No Heatsink, Free Air)	R_{JA}	260	°C/W
Maximum Junction Temperature	T_J	-40~150	°C
Operating Junction Temperature	T_J	-40~125	°C
Storage Temperature	T_{STG}	-65~150	°C
Lead Temperature (Soldering, 10 sec)	T_{LEAD}	260	°C
ESD (HBM)		>4000	V

Note1: Stresses greater than those listed under Maximum Ratings may cause permanent damage to the device. This is a stress rating only and functional operation of the device at these or any other conditions above those indicated in the operation is not implied. Exposure to absolute maximum rating conditions for extended periods may affect reliability.

500mA 1.2MHz 36V Built in SBD Boost DC/DC Converter

XL6107

XL6107 Electrical Characteristics

$T_A = 25^\circ\text{C}$; system parameters test circuit figure5, unless otherwise specified.

Symbol	Parameter	Test Condition	Min.	Typ.	Max.	Unit
V_{FB}	Feedback Voltage	$V_{IN} = 5V, V_{OUT} = 12V$ $I_{OUT} = 30mA$	401.8	410	418.2	mV
η	Efficiency	$V_{IN} = 5V, V_{OUT} = 12V$ $I_{OUT} = 50mA$	-	83.2	-	%
η	Efficiency	$V_{IN} = 12V, V_{OUT} = 24V$ $I_{OUT} = 0.1A$	-	87.3	-	%

Electrical Characteristics (DC Parameters)

$T_A = 25^\circ\text{C}, V_{IN} = 3V$; system parameters test circuit figure4, unless otherwise specified.

Parameters	Symbol	Test Condition	Min.	Typ.	Max.	Unit
Input operation voltage	V_{IN}		2.5		20	V
Shutdown Supply Current	I_S	$V_{EN} = 0V$ V_{OUT} flowing		3		μA
Quiescent Supply Current	I_Q	$V_{FB} = 2V$		2.3		mA
Oscillator Frequency	F_{OSC}		0.96	1.20	1.44	MHz
Switch Current Limit	I_L	$V_{FB} = 0V$		500		mA
Switch V_{CE} Saturation Voltage	V_{SAT}	$I_{SW} = 300mA$		0.3		V
Schottky Forward Drop	V_F	$I_F = 300mA$		0.8		V
EN Pin Threshold	V_{EN_H}	High(ON)	2.0			V
	V_{EN_L}	Low(OFF)			0.5	
Max. Duty Cycle	D_{MAX}	$V_{FB} = 0V$		90		%
Over Voltage Protection	V_{OUT}	$V_{FB} = 0V$		36		V
Thermal Shutdown Temperature	T_{SD}			150		$^\circ\text{C}$

Typical System Application–Single Li Battery Boost Driver Circuit ($V_{OUT}=5.0V$)

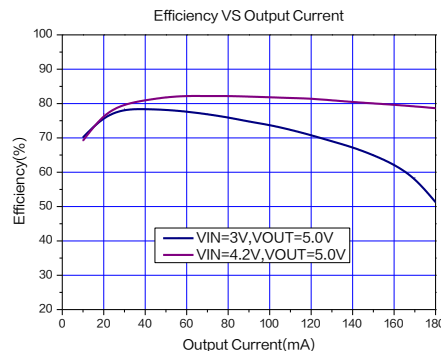
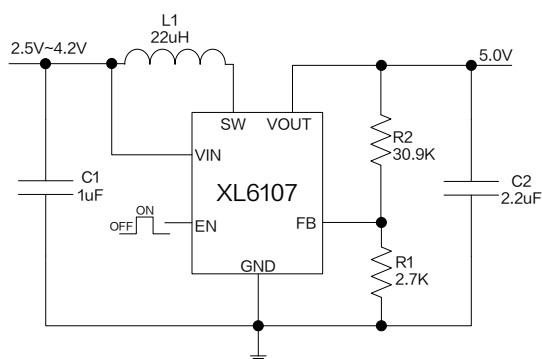

Figure4. XL6107 System Application and efficiency curve ($V_{OUT}=5.0V$)

Table 2. Figure4 Typical System Application Schematic Boom

Qty	Ref Des	Description	Mfg Part Number	Mfg
1	L1	22uH,0.53A,Inductor,3*3	ANR3015T220M	APV
1	C1	1uF,25V,Ceramic,X7R,0603	0603B105K250NT	Fenghua
1	C2	2.2uF,50V,Ceramic,X7R,0805	0805X225K500NT	Fenghua
1	R1	2.7K Ω ,1%,1/16W,Thick Film,0603	RS-03K2701FT	Fenghua
1	R2	30.9K Ω ,1%,1/16W,Thick Film,0603	RS-03K3092FT	Fenghua

Typical System Application–Two Li Batteries Boost Driver Circuit ($V_{OUT}=12V$)

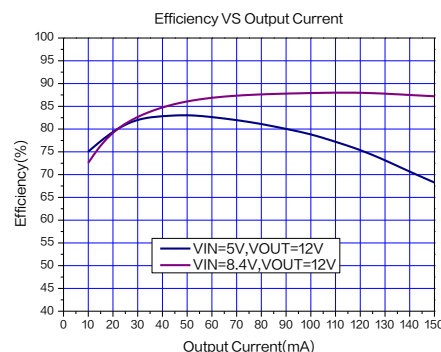
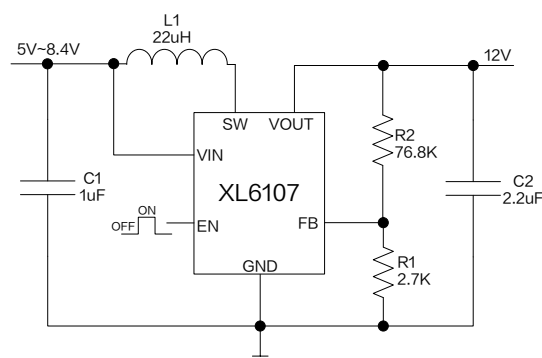
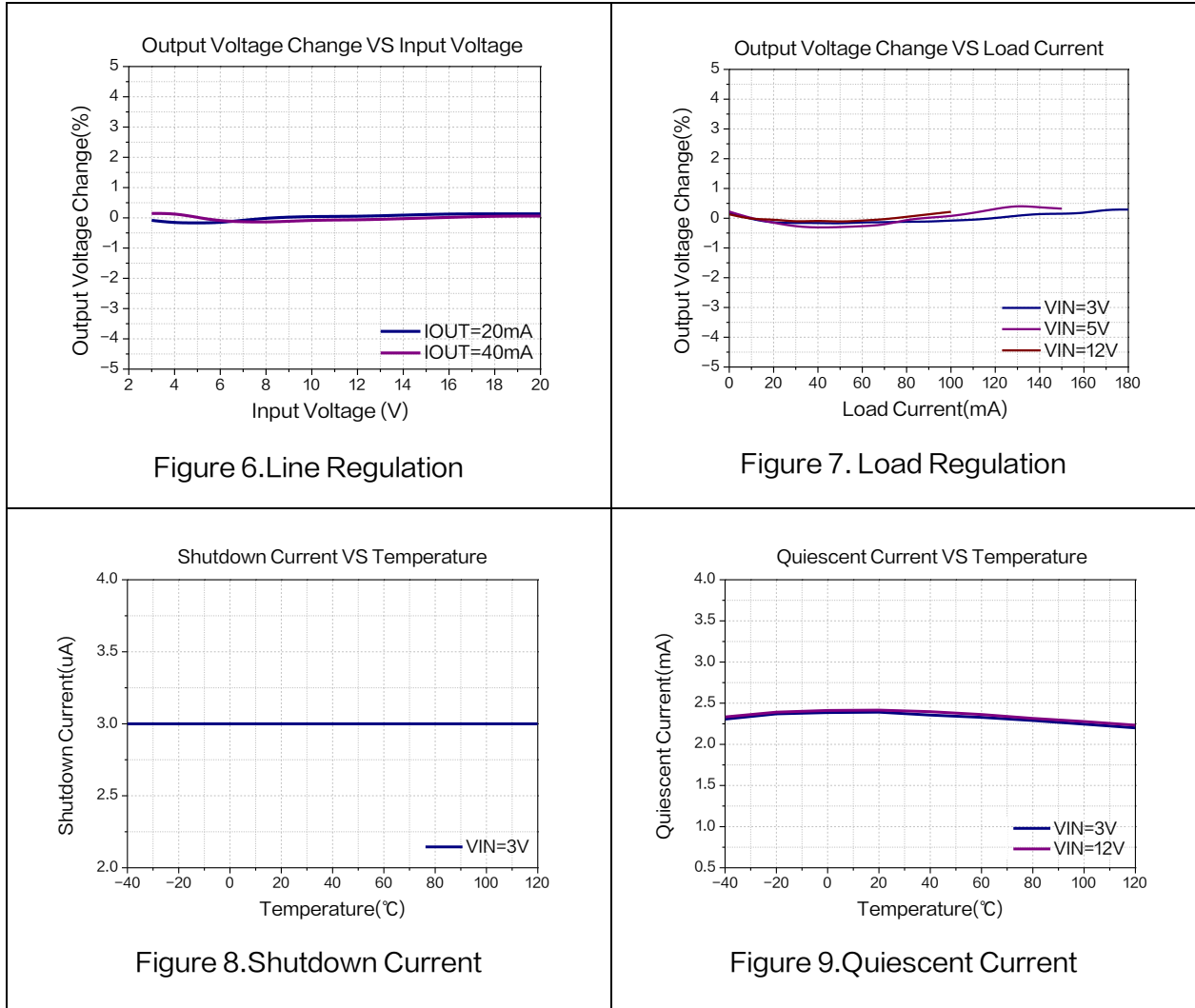

Figure5. XL6107 System Application and efficiency curve ($V_{OUT}=12V$)

Table 3. Figure5 Typical System Application Schematic Boom

Qty	Ref Des	Description	Mfg Part Number	Mfg
1	L1	22uH,0.53A,Inductor,3*3	ANR3015T220M	APV
1	C1	1uF,25V,Ceramic,X7R,0603	0603B105K250NT	Fenghua
1	C2	2.2uF,50V,Ceramic,X7R,0805	0805X225K500NT	Fenghua
1	R1	2.7K Ω ,1%,1/16W,Thick Film,0603	RS-03K2701FT	Fenghua
1	R2	76.8K Ω ,1%,1/16W,Thick Film,0603	RS-03K7682FT	Fenghua

Typical Characteristics



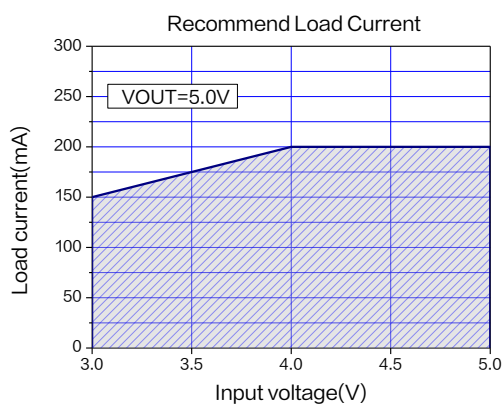

Figure 10. Max Output Current
(V_{OUT}=5.0V, T_A=25°C)

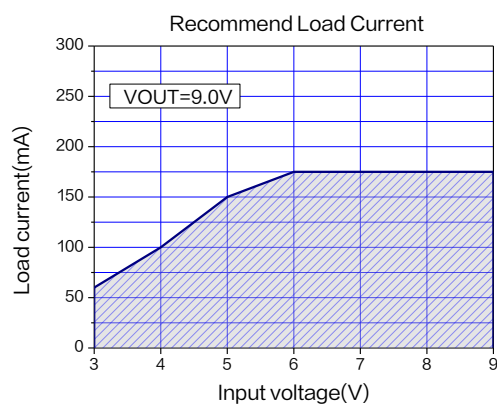

Figure 11. Max Output Current
(V_{OUT}=9.0V, T_A=25°C)

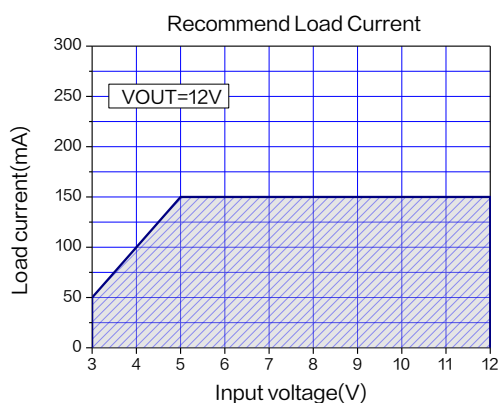

Figure 12. Max Output Current
(V_{OUT}=12V, T_A=25°C)

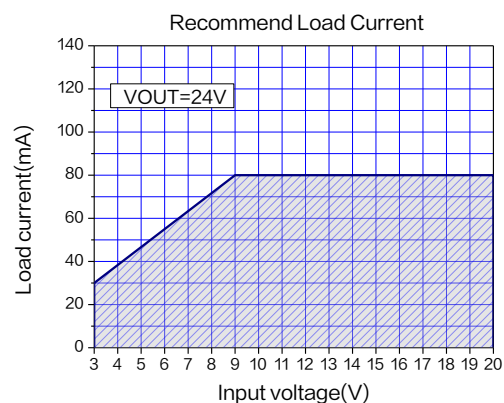
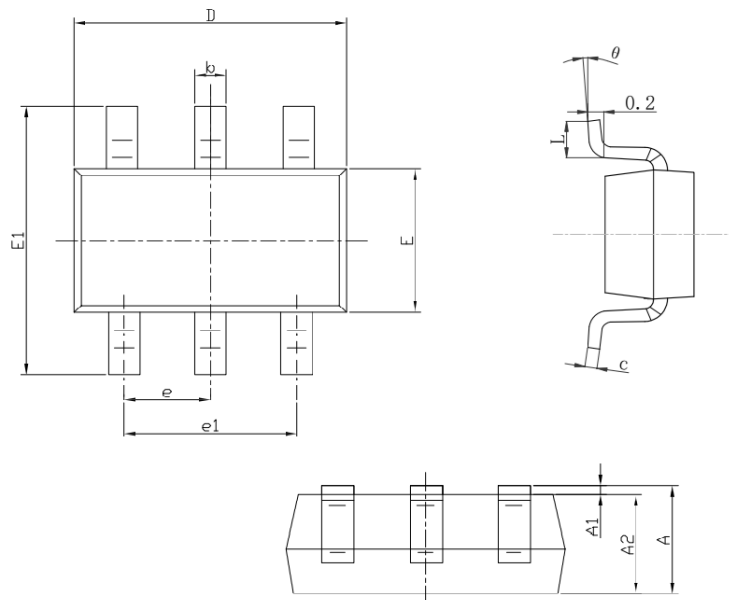

Figure 13. Max Output Current
(V_{OUT}=24V, T_A=25°C)

Package Information

SOT23-6



Symbol	Dimensions In Millimeters		Dimensions In Inches	
	Min.	Max.	Min.	Max.
A	1.000	1.350	0.039	0.053
A1	0.000	0.150	0.000	0.006
A2	1.000	1.200	0.039	0.047
b	0.300	0.500	0.012	0.020
c	0.100	0.200	0.004	0.008
D	2.820	3.050	0.111	0.120
E	1.500	1.726	0.059	0.068
E1	2.600	3.000	0.102	0.118
e	0.900	1.000	0.035	0.039
e1	1.800	2.000	0.071	0.079
L	0.300	0.600	0.012	0.024
θ	0°	8°	0°	8°

500mA 1.2MHz 36V Built in SBD Boost DC/DC Converter	XL6107
---	--------

Important Notice

XLSEMI reserve the right to make modifications, enhancements, improvements, corrections or other changes without notice at any time. XLSEMI does not assume any liability arising out of the application or use of any product described herein; neither does it convey any license under its patent rights, nor the rights of others. XLSEMI assumes no liability for applications assistance or the design of Buyers' products. Buyers are responsible for their products and applications using XLSEMI components. To minimize the risks associated with Buyers' products and applications, Buyers should provide adequate design and operating safeguards. XLSEMI warrants performance of its products to the specifications applicable at the time of sale, in accordance with the warranty in XLSEMI's terms and conditions of sale of semiconductor products. Testing and other quality control techniques are used to the extent XLSEMI deems necessary to support this warranty. Except where mandated by applicable law, testing of all parameters of each component is not necessarily performed.

For the latest product information, go to www.xlsemi.com.