

0.4A 150KHz 100V Buck DC to DC Converter

XL7005A

Features

- Operating Voltage: 5V~80V
- Output Adjustable from 1.25V to 20V
- Maximum Duty Cycle 90%
- Minimum Drop Out 2V
- Fixed 150KHz Switching Frequency
- Maximum 0.4A Output Current
- Recommend output power less than 5W
- Internal Optimize HV Power Transistor
- High efficiency up to 85%
- Excellent line and load regulation
- TTL shutdown capability
- Built in thermal shutdown function
- Built in output short Protection Function
- Built in current limit function
- SOP8-EP (Exposed PAD) package

Applications

- Ebike Controller Power Supply
- Telecom / Networking Equipment

General Description

The XL7005A is a 150KHz fixed frequency PWM buck (step-down) DC/DC converter, capable of driving a 0.4A load with high efficiency, low ripple and excellent line and load regulation. Requiring a minimum number of external components, the regulator is simple to use and include internal frequency compensation and a fixed-frequency oscillator.

The PWM control circuit is able to adjust the duty ratio linearly from 0 to 90%. An enable function, an over current protection function is built inside. When output short protection function happens, the operation frequency will be reduced from 150KHz to 45KHz. An internal compensation block is built in to minimize external component count.

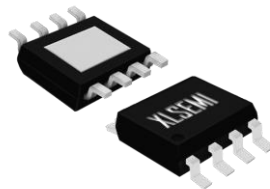

Figure1. Package Type of XL7005A

Pin Configurations

VIN	1	8	GND
SW	2	7	GND
XL7005A			
FB	3	6	GND
EN	4	5	GND

The Exposed PAD is GND

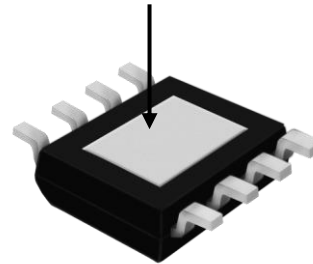

Figure2. Pin Configuration of XL7005A

Table 1 Pin Description

Pin Number	Pin Name	Description
1	VIN	Supply Voltage Input Pin. Bypass Vin to GND with a suitably large capacitor to eliminate noise on the input.
2	SW	Power Switch Output Pin (SW). Output is the switch node that supplies power to the output.
3	FB	Feedback Pin (FB). Through an external resistor divider network, Feedback senses the output voltage and regulates it. The feedback threshold voltage is 1.25V.
4	EN	Enable Pin. Drive EN pin low to turn on the device, drive it high to turn it off. Floating is default low.
5~8	GND	Ground Pin. Care must be taken in layout. This pin should be placed outside of the Schottky Diode to output capacitor ground path to prevent switching current spikes from inducing voltage noise into XL7005A. The exposed PAD is GND.

Function Block

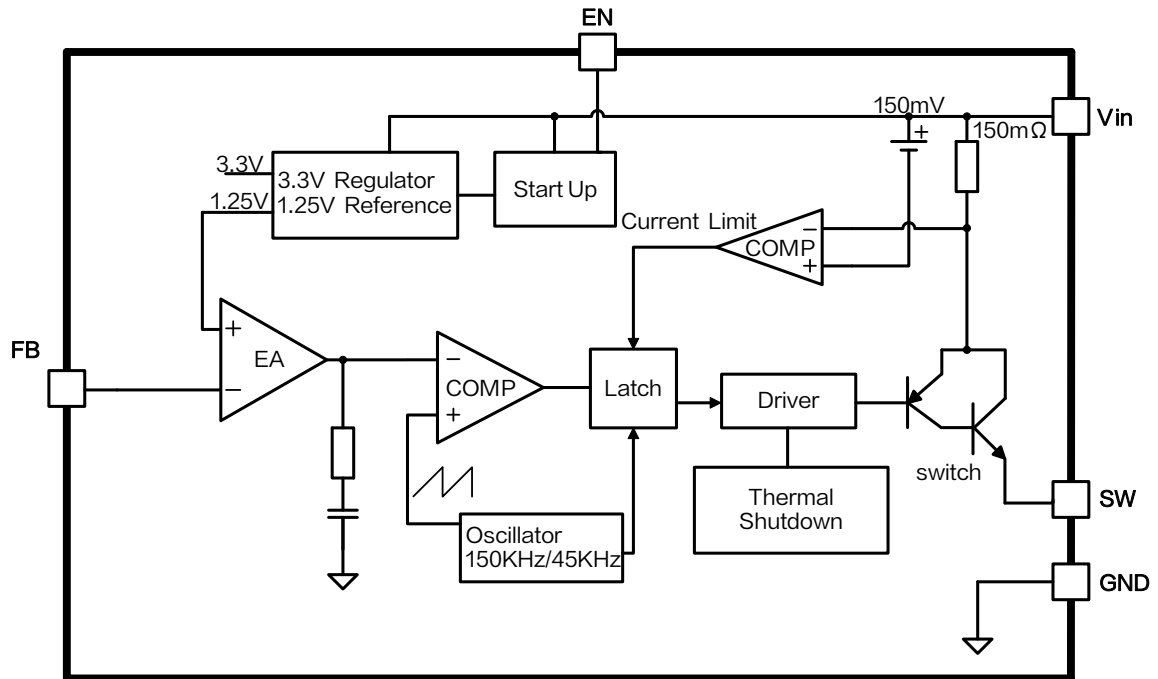

Figure3. Function Block Diagram of XL7005A

Typical Application Circuit

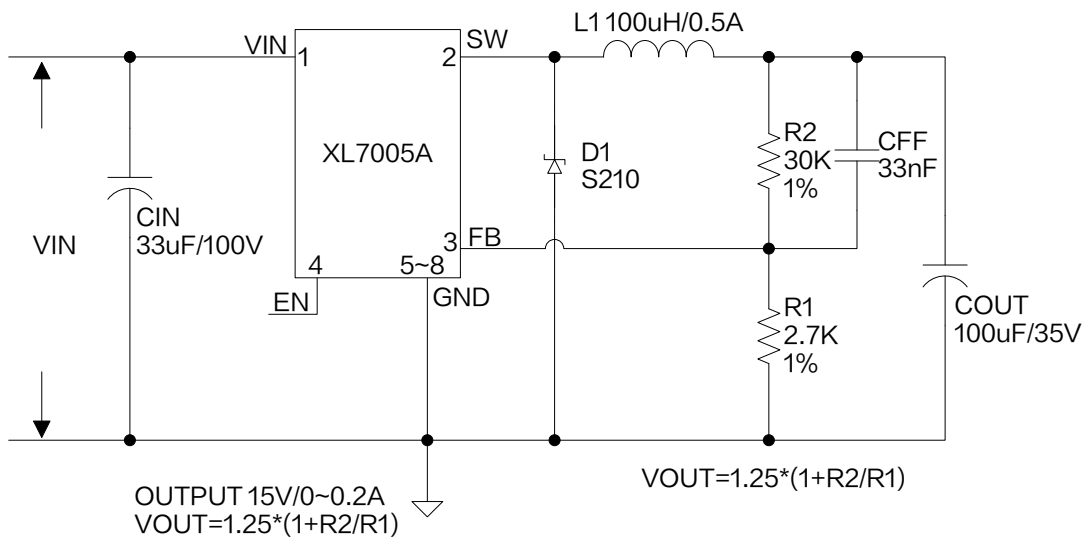

Figure4. XL7005A Typical Application Circuit

0.4A 150KHz 100V Buck DC to DC Converter

XL7005A

Ordering Information

Order Information	Marking ID	Package Type	Eco Plan	Packing Type Supplied As
XL7005A	XL7005A	SOP8-EP	RoHS & HF	4000 Units on Tape & Reel

Absolute Maximum Ratings (Note1)

Parameter	Symbol	Value	Unit
Input Voltage	V _{IN}	-0.3 to 100	V
Feedback Pin Voltage	V _{FB}	-0.3 to 7	V
EN Pin Voltage	V _{EN}	-0.3 to 7	V
Output Switch Pin Voltage	V _{SW}	-0.3 to V _{IN}	V
Power Dissipation	P _D	Internally limited	mW
Thermal Resistance (SOP8-EP) (Junction to Ambient, No Heatsink, Free Air)	R _{JA}	60	°C/W
Maximum Junction Temperature	T _J	-40 to 150	°C
Operating Junction Temperature	T _J	-40 to 125	°C
Storage Temperature	T _{STG}	-65 to 150	°C
Lead Temperature (Soldering, 10 sec)	T _{LEAD}	260	°C
ESD (HBM)		>3000	V

Note1: Stresses greater than those listed under Maximum Ratings may cause permanent damage to the device. This is a stress rating only and functional operation of the device at these or any other conditions above those indicated in the operation is not implied. Exposure to absolute maximum rating conditions for extended periods may affect reliability.

0.4A 150KHz 100V Buck DC to DC Converter

XL7005A

XL7005A Electrical Characteristics

T_a = 25°C; unless otherwise specified.

Symbol	Parameter	Test Condition	Min.	Typ.	Max.	Unit
System parameters test circuit figure4						
VFB	FB Voltage	V _{in} =20V to 80V, V _{out} =15V I _{load} =0.1A to 0.2A	1.225	1.25	1.275	V
η	Efficiency	V _{in} =36V, V _{out} =15V I _{out} =0.2A	-	86	-	%
η	Efficiency	V _{in} =48V, V _{out} =15V I _{out} =0.2A	-	81	-	%
η	Efficiency	V _{in} =60V, V _{out} =15V I _{out} =0.2A	-	75	-	%

Electrical Characteristics (DC Parameters)

V_{in} = 48V, GND=0V, V_{in} & GND parallel connect a 33uf/100V capacitor; I_{out}=0.2A, T_a = 25°C; the others floating unless otherwise specified.

Parameters	Symbol	Test Condition	Min.	Typ.	Max.	Unit
Input operation voltage	V _{in}		5		80	V
Shutdown Supply Current	I _s	V _{EN} =2V		85	200	uA
Quiescent Supply Current	I _q	V _{EN} =0V, V _{FB} =2V		2.5	5	mA
Oscillator Frequency	F _{osc}		120	150	180	KHz
Switch Current Limit	I _L	V _{FB} =0V		0.5		A
EN Pin Threshold	V _{EN}	High (Regulator OFF)		1.6		V
		Low (Regulator ON)		0.8		
EN Pin Input Leakage Current	I _H	V _{EN} =2.5V (OFF)		6	20	uA
	I _L	V _{EN} =0.5V (ON)		1	10	uA
Output Saturation Voltage	V _{CE}	V _{FB} =0V I _{out} =0.4A		0.87		V
Max. Duty Cycle	D _{MAX}	V _{FB} =0V		90		%

Typical System Application (Recommend output current safe work range)

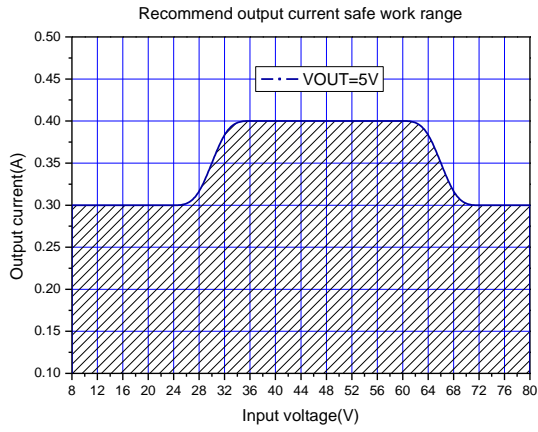

Figure5.Max output current(VOUT=5V)

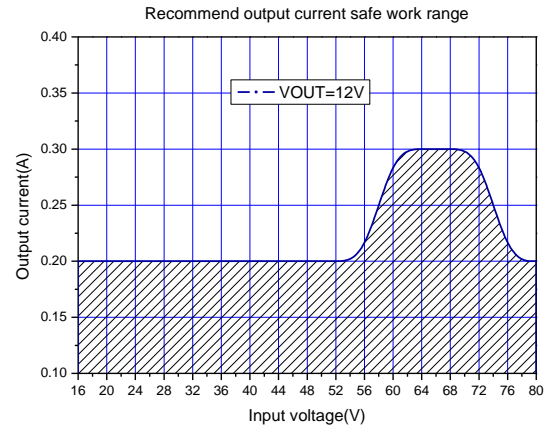

Figure6.Max output current(VOUT=12V)

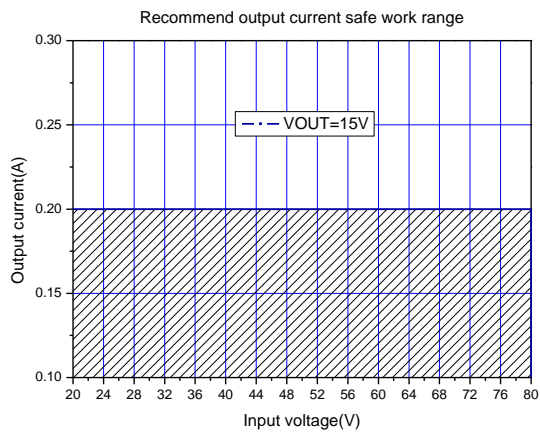

Figure7.Max output current(VOUT=15V)

Typical System Application(V_{OUT}=15V/0.2A)

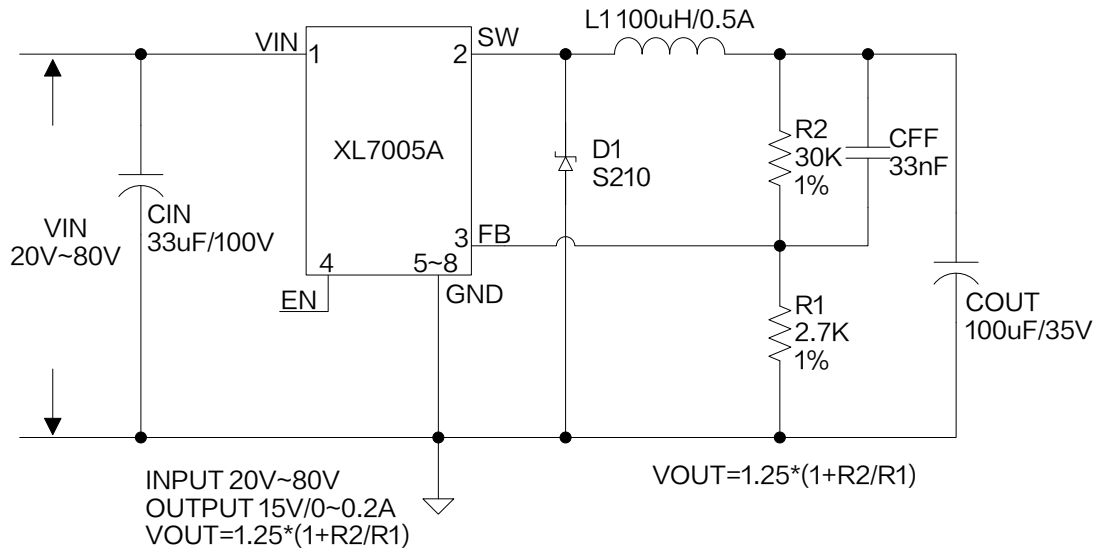

Figure8. XL7005A System Application (V_{IN}=20V~80V, V_{OUT}=15V/0.2A)

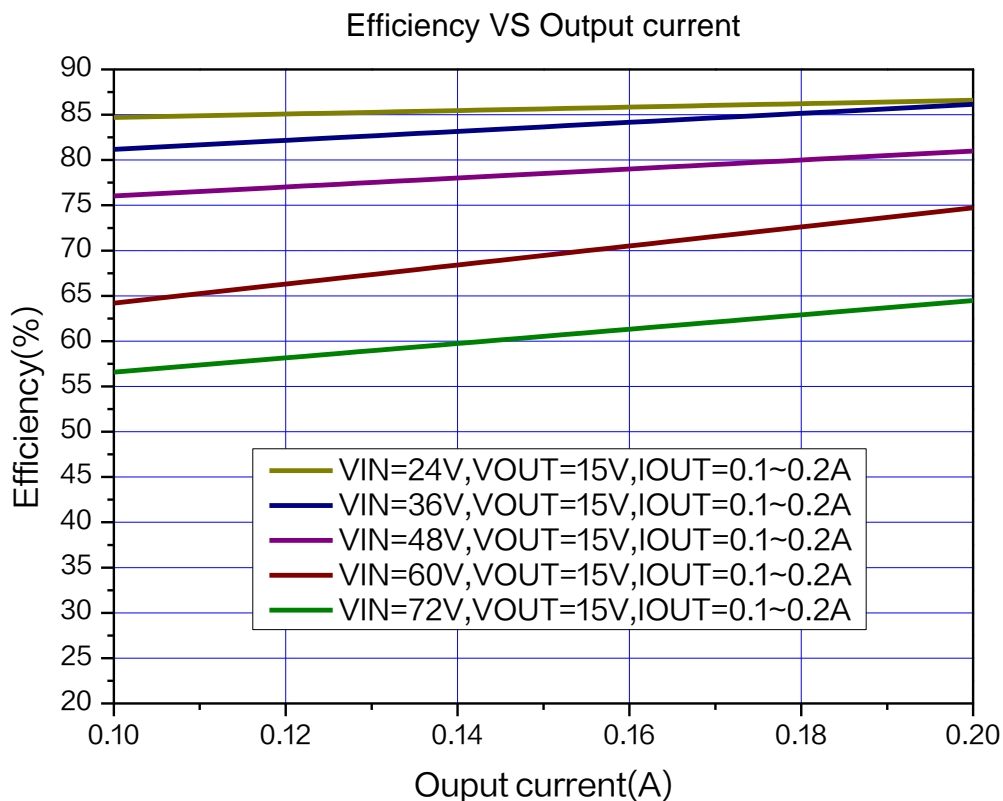

Figure9. XL7005A System Application (Efficiency VS Output Current)

Typical System Application(VOUT=5V/0.4A)

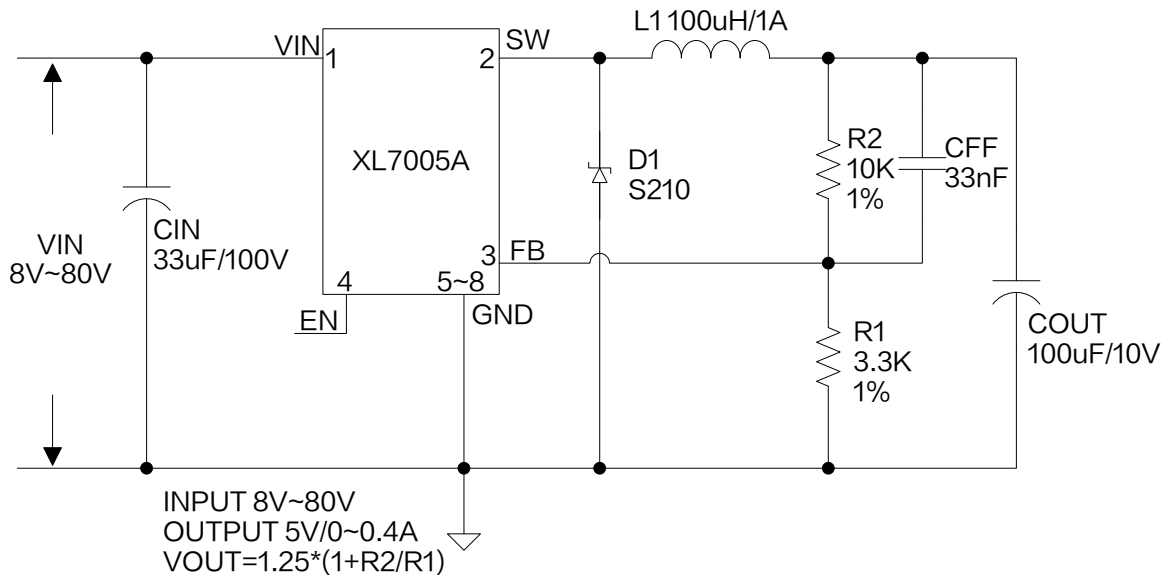

Figure10. XL7005A System Application (VIN=8V~80V, VOUT=5V/0.4A)

Efficiency VS Output current

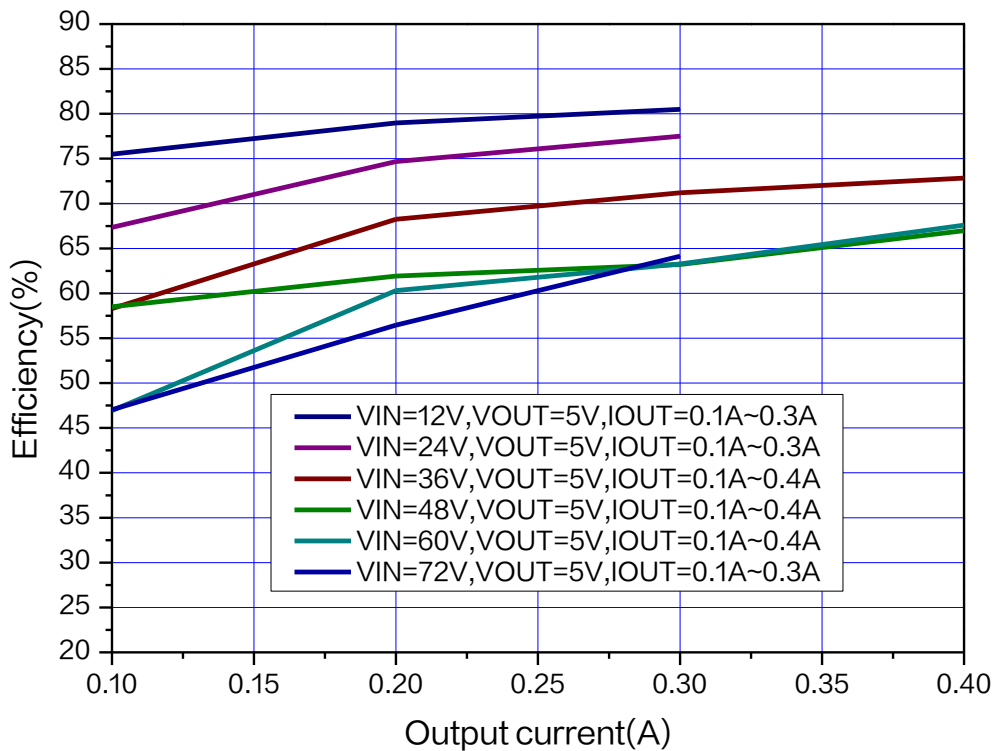
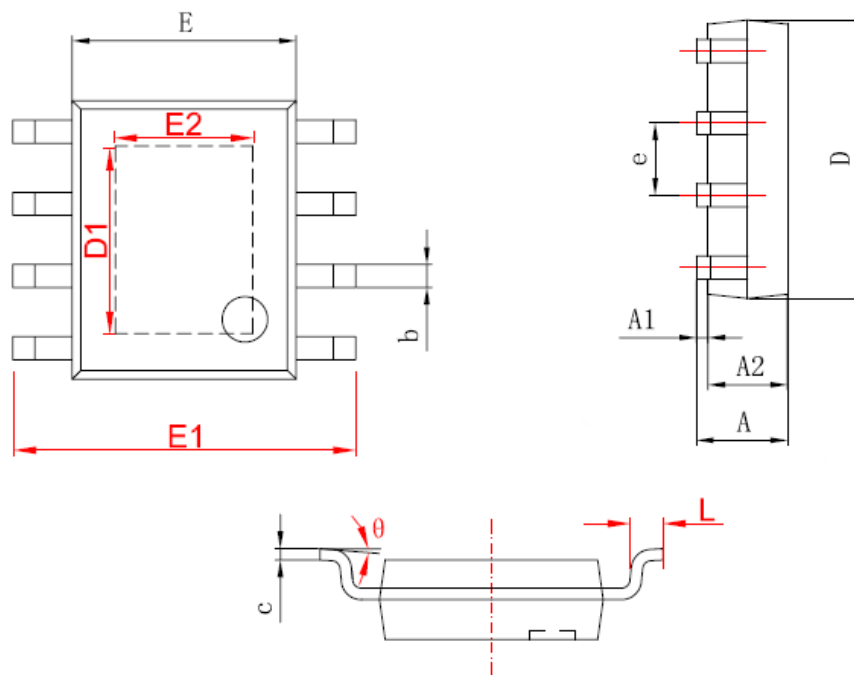

Figure11. XL7005A System Application (Efficiency VS Output Current)

Package Information

SOP8-EP



Symbol	Dimensions In Millimeters		Dimensions In Inches	
	Min.	Max.	Min.	Max.
A	1.350	1.750	0.053	0.069
A1	0.000	0.150	0.000	0.006
A2	1.250	1.650	0.049	0.065
b	0.306	0.510	0.012	0.020
c	0.170	0.250	0.007	0.010
D	4.700	5.100	0.185	0.201
D1	2.650	3.467	0.104	0.136
E	3.800	4.000	0.150	0.157
E1	5.800	6.200	0.228	0.244
E2	1.910	2.534	0.075	0.100
e	1.140	1.400	0.045	0.055
L	0.450	0.800	0.018	0.031
θ	0°	8°	0°	8°

0.4A 150KHz 100V Buck DC to DC Converter	XL7005A
--	---------

Important Notice

XLSEMI reserve the right to make modifications, enhancements, improvements, corrections or other changes without notice at any time. XLSEMI does not assume any liability arising out of the application or use of any product described herein; neither does it convey any license under its patent rights, nor the rights of others. XLSEMI assumes no liability for applications assistance or the design of Buyers' products. Buyers are responsible for their products and applications using XLSEMI components. To minimize the risks associated with Buyers' products and applications, Buyers should provide adequate design and operating safeguards. XLSEMI warrants performance of its products to the specifications applicable at the time of sale, in accordance with the warranty in XLSEMI's terms and conditions of sale of semiconductor products. Testing and other quality control techniques are used to the extent XLSEMI deems necessary to support this warranty. Except where mandated by applicable law, testing of all parameters of each component is not necessarily performed.

For the latest product information, go to www.xlsemi.com.