

Features

- Operating Voltage: 10V~80V
- Output Adjustable from 1.25V to 20V
- Maximum Duty Cycle 100%
- Minimum Drop Out 1V
- Fixed 100KHz Switching Frequency
- Max. IOU=0.3A at VOUT=5V
- Max. IOU=0.2A at VOUT=12V or 15V
- Internal Optimize HV Power Transistor
- High efficiency up to 84%
- Excellent line and load regulation
- Built in thermal shutdown function
- Built in current limit function
- Built in output short Protection Function
- SOP8-EP (Exposed PAD) package

Applications

- Ebike Controller Power Supply
- Telecom / Networking Equipment

General Description

The XL7045 is a 100KHz fixed frequency PWM buck (step-down) DC/DC converter, capable of driving a 0.3A load with high efficiency, low ripple and excellent line and load regulation. Requiring a minimum number of external components, the regulator is simple to use and include internal frequency compensation and a fixed-frequency oscillator.

The PWM control circuit is able to adjust the duty ratio linearly from 0 to 100%. An enable function, an over current protection function is built inside. When output short protection function happens, the operation frequency will be reduced from 100KHz to 15KHz. An internal compensation block is built in to minimize external component count.

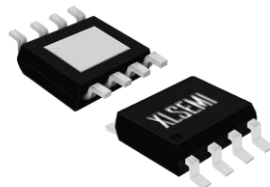

Figure1. Package Type of XL7045

Pin Configurations

| | | | |
|--------|---|---|-----|
| VIN | 1 | 8 | NC |
| SW | 2 | 7 | NC |
| XL7045 | | | |
| FB | 3 | 6 | CSN |
| GND | 4 | 5 | CSP |

The Exposed PAD is GND

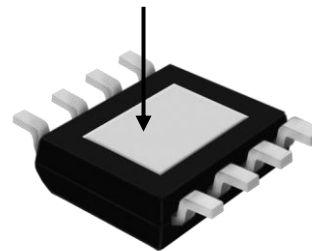

Figure2. Pin Configuration of XL7045

Table 1 Pin Description

| Pin Number | Pin Name | Description |
|------------|----------|--|
| 1 | VIN | Supply Voltage Input Pin. Bypass Vin to GND with a suitably large capacitor to eliminate noise on the input. |
| 2 | SW | Power Switch Output Pin (SW). Output is the switch node that supplies power to the output. |
| 3 | FB | Feedback Pin (FB). Through an external resistor divider network, Feedback senses the output voltage and regulates it. The feedback threshold voltage is 1.25V. |
| 4 | GND | Ground Pin. Care must be taken in layout. This pin should be placed outside of the Schottky Diode to output capacitor ground path to prevent switching current spikes from inducing voltage noise into XL7045. The exposed PAD is GND. |
| 5 | CSP | Current Sense Positive Terminal Pin. |
| 6 | CSN | Current Sense Negative Terminal Pin. |
| 7~8 | NC | No Connected. |

0.3A 100KHz 100V Buck DC to DC Converter

XL7045

Function Block

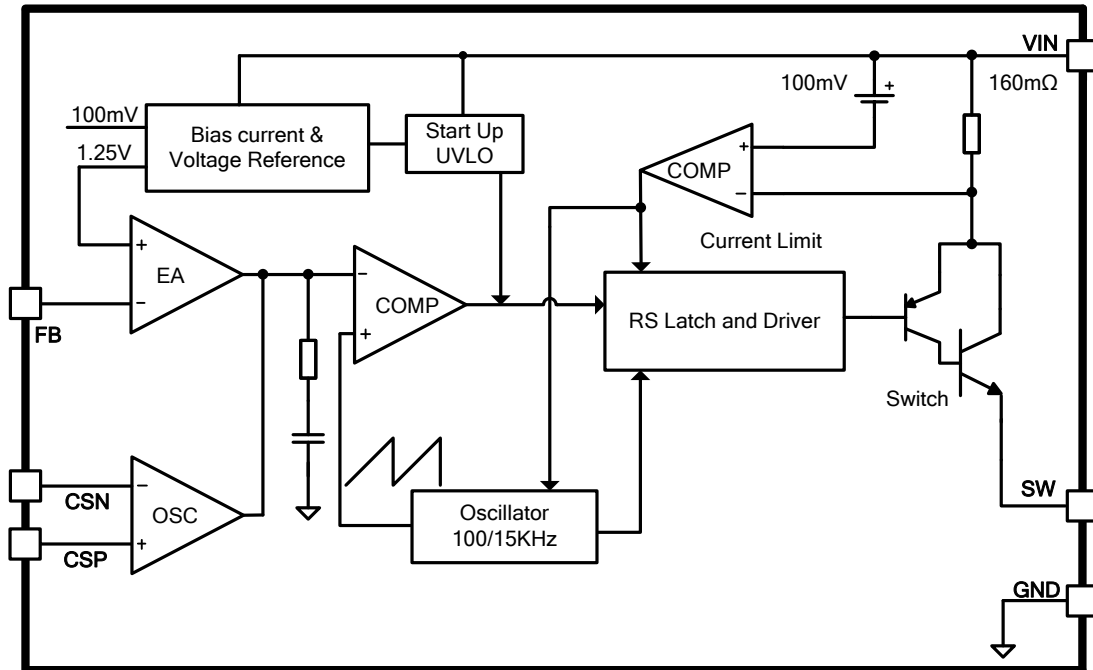

Figure3. Function Block Diagram of XL7045

Typical Application Circuit

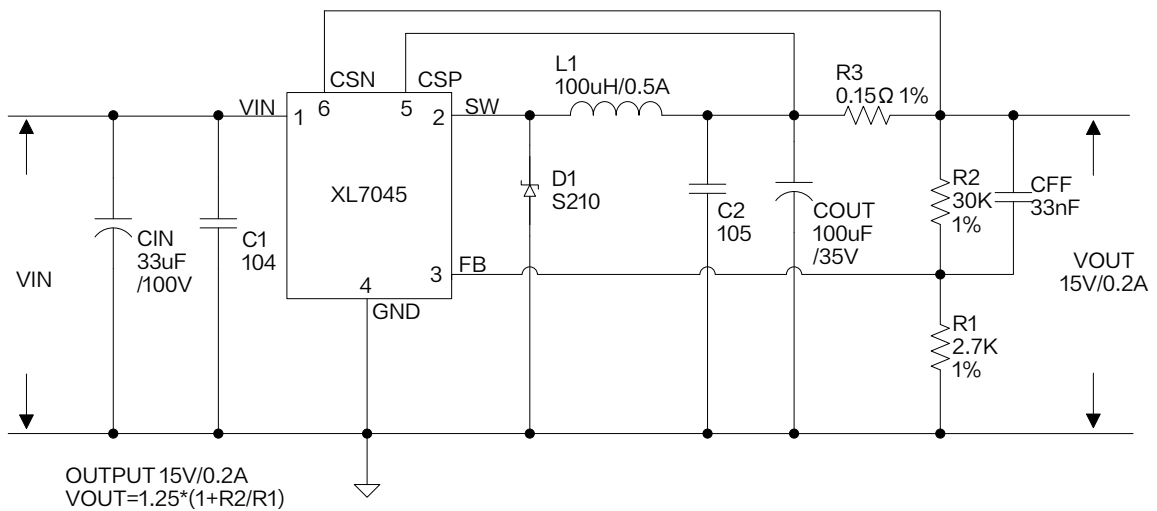

Figure4. XL7045 Typical Application Circuit

0.3A 100KHz 100V Buck DC to DC Converter

XL7045

Ordering Information

| Order Information | Marking ID | Package Type | Eco Plan | Packing Type Supplied As |
|-------------------|------------|--------------|-----------|---------------------------|
| XL7045E1 | XL7045E1 | SOP8-EP | RoHS & HF | 4000 Units on Tape & Reel |

Absolute Maximum Ratings (Note1)

| Parameter | Symbol | Value | Unit |
|--|------------|--------------------|------|
| Input Voltage | V_{in} | -0.3 to 100 | V |
| Feedback Pin Voltage | V_{FB} | -0.3 to V_{in} | V |
| Output Switch Pin Voltage | V_{SW} | -0.3 to V_{in} | V |
| CSP Pin Voltage | V_{CSP} | -0.3 to 20 | V |
| CSN Pin Voltage | V_{CSN} | -0.3 to 20 | V |
| Power Dissipation | P_D | Internally limited | mW |
| Thermal Resistance (SOP8-EP) (Junction to Ambient, No Heatsink, Free Air) | R_{JA} | 60 | °C/W |
| Maximum Junction Temperature | T_J | -40 to 150 | °C |
| Operating Junction Temperature | T_J | -40 to 125 | °C |
| Storage Temperature | T_{STG} | -65 to 150 | °C |
| Lead Temperature (Soldering, 10 sec) | T_{LEAD} | 260 | °C |

Note1: Stresses greater than those listed under Maximum Ratings may cause permanent damage to the device. This is a stress rating only and functional operation of the device at these or any other conditions above those indicated in the operation is not implied. Exposure to absolute maximum rating conditions for extended periods may affect reliability.

0.3A 100KHz 100V Buck DC to DC Converter

XL7045

XL7045 Electrical Characteristics

T_a = 25°C; unless otherwise specified.

| Symbol | Parameter | Test Condition | Min. | Typ. | Max. | Unit |
|---|------------|---|-------|------|-------|------|
| System parameters test circuit figure4 | | | | | | |
| VFB | FB Voltage | Vin =20V to 80V, Vout=15V Iload=0.1A to 0.2A | 1.225 | 1.25 | 1.275 | V |
| η | Efficiency | Vin=36V, Vout=15V Iout=0.2A | - | 84 | - | % |
| η | Efficiency | Vin=48V, Vout=15V Iout=0.2A | - | 81 | - | % |
| η | Efficiency | Vin=60V, Vout=15V Iout=0.2A | - | 77 | - | % |

Electrical Characteristics (DC Parameters)

Vin = 48V, GND=0V, Vin & GND parallel connect a 33uf/100V capacitor; Iout=0.2A, T_a = 25°C; the others floating unless otherwise specified.

| Parameters | Symbol | Test Condition | Min. | Typ. | Max. | Unit |
|---------------------------|------------------|--|------|------|------|------|
| Input operation voltage | Vin | | 10 | | 80 | V |
| VIN UVLO | Vin_uvlo | | | 8 | 9 | V |
| Quiescent Supply Current | I _q | V _{FB} =2V | | 2.8 | 5 | mA |
| Oscillator Frequency | Fosc | | 75 | 100 | 125 | KHz |
| Switch Current Limit | I _L | V _{FB} =0V R3=0.15Ω | | 0.35 | | A |
| Output Saturation Voltage | V _{CE} | V _{FB} =0V I _{SW} =0.3A | | 0.84 | | V |
| Max. Duty Cycle | D _{MAX} | V _{FB} =0V | | 100 | | % |

Typical Performance Characteristics

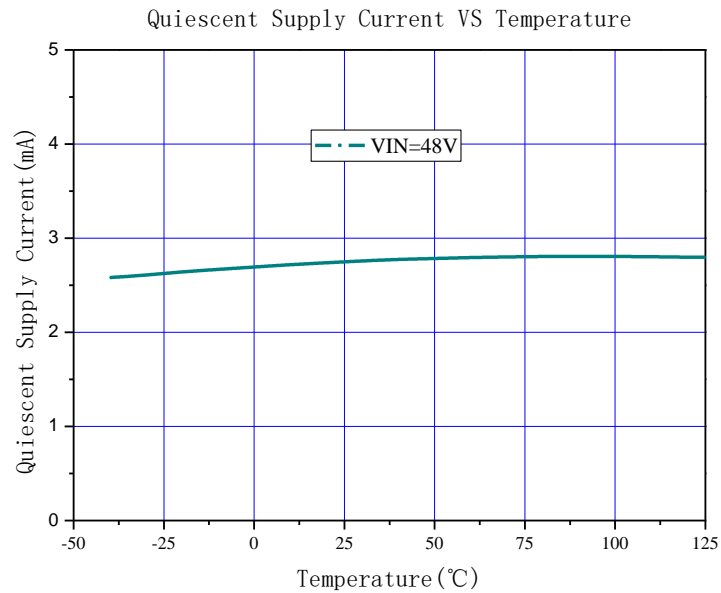

Figure5. Quiescent Current Curve

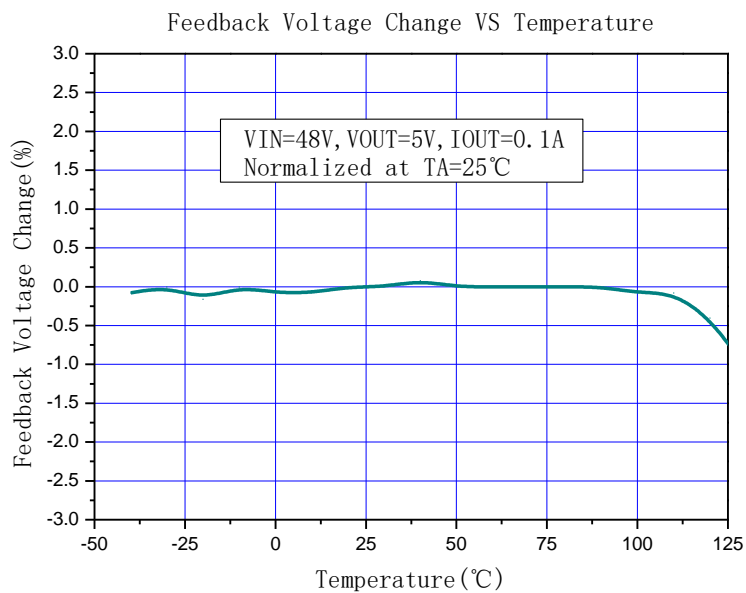

Figure6. Feedback Voltage Curve

0.3A 100KHz 100V Buck DC to DC Converter

XL7045

Typical System Application(V_{OUT}=15V/0.2A)

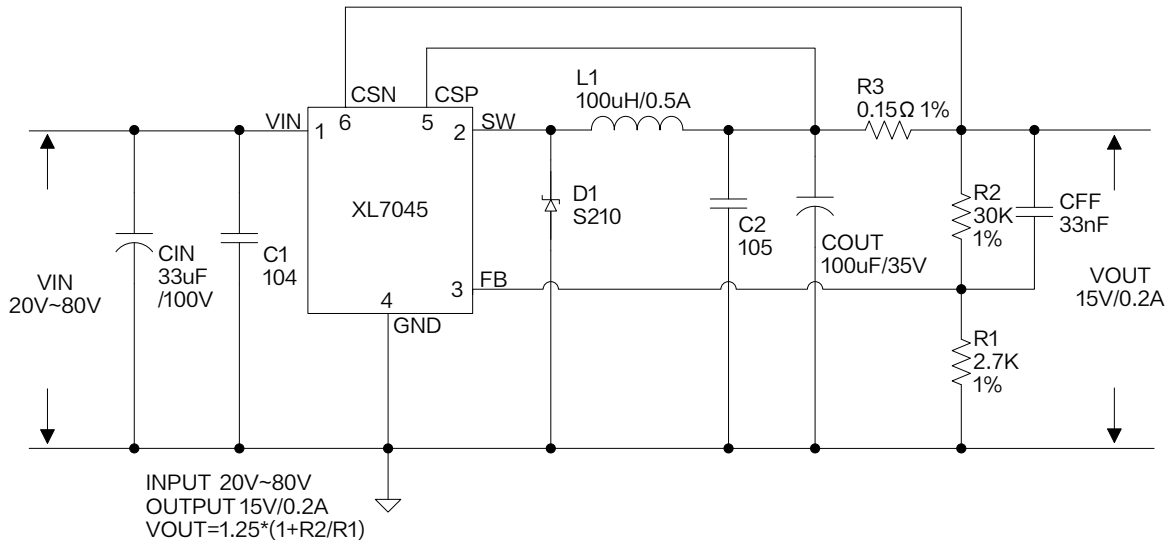

Figure7. XL7045 System Application (VIN=20V~80V, V_{OUT}=15V/0.2A)

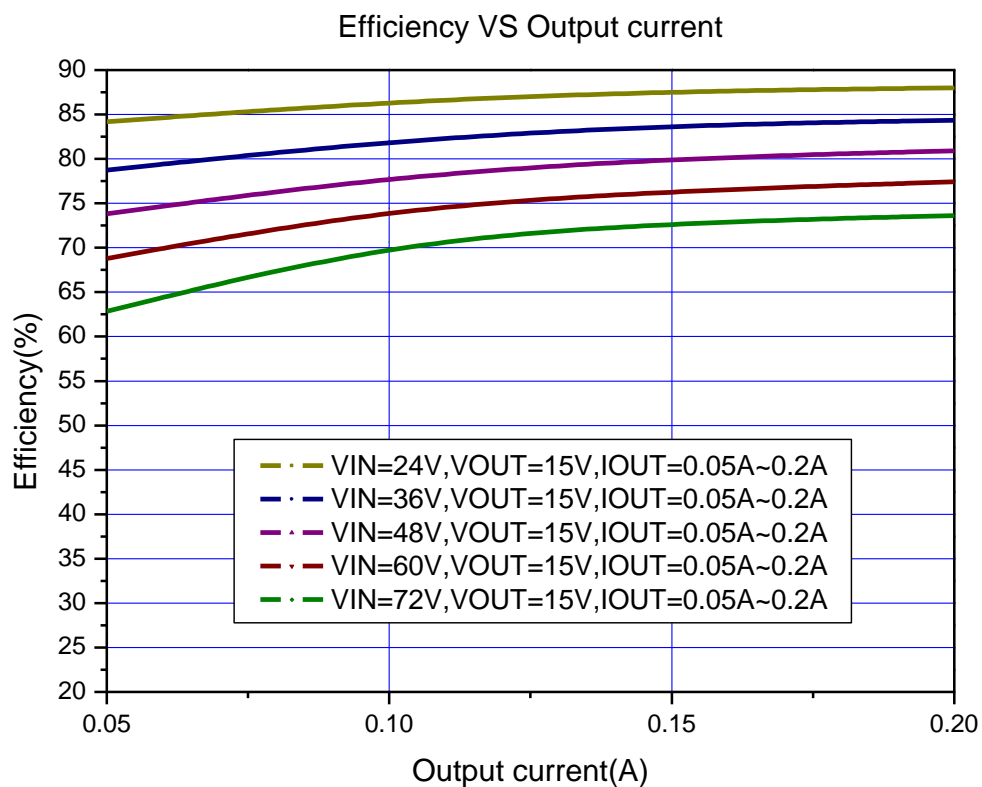

Figure8. XL7045 System Application (Efficiency VS Output Current)

0.3A 100KHz 100V Buck DC to DC Converter

XL7045

Typical System Application(VOUT=5V/0.3A)

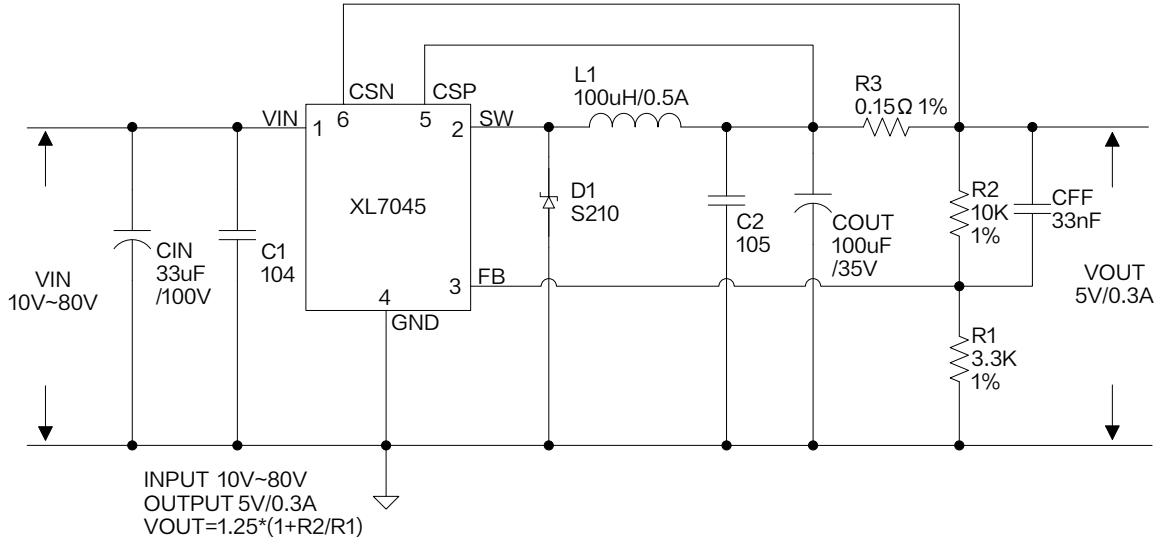

Figure9. XL7045 System Application (VIN=10V~80V, VOUT=5V/0.3A)

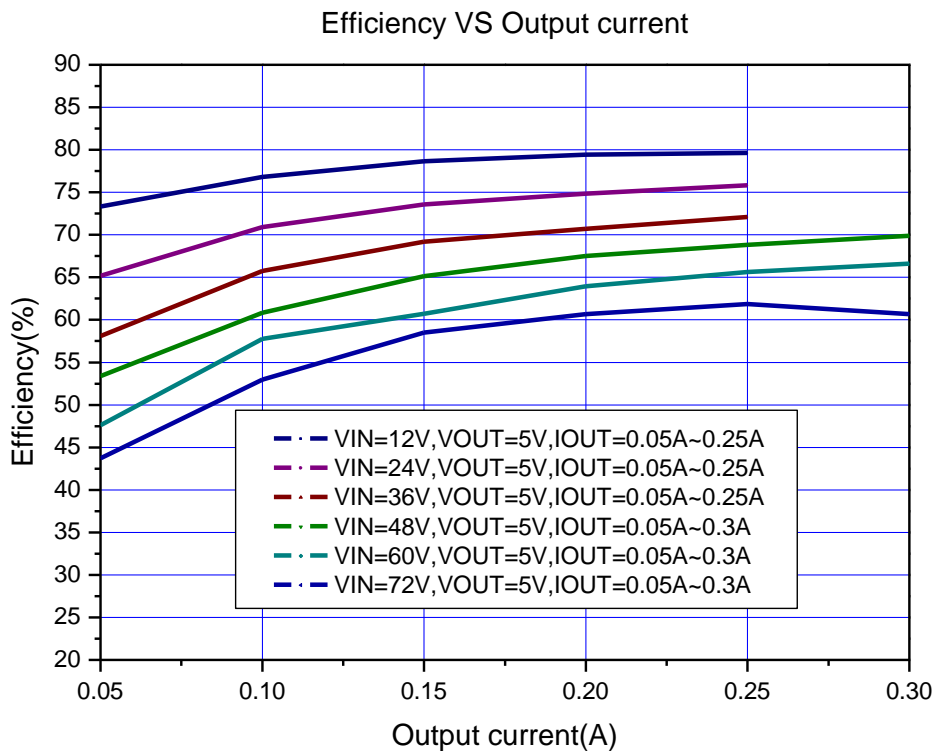
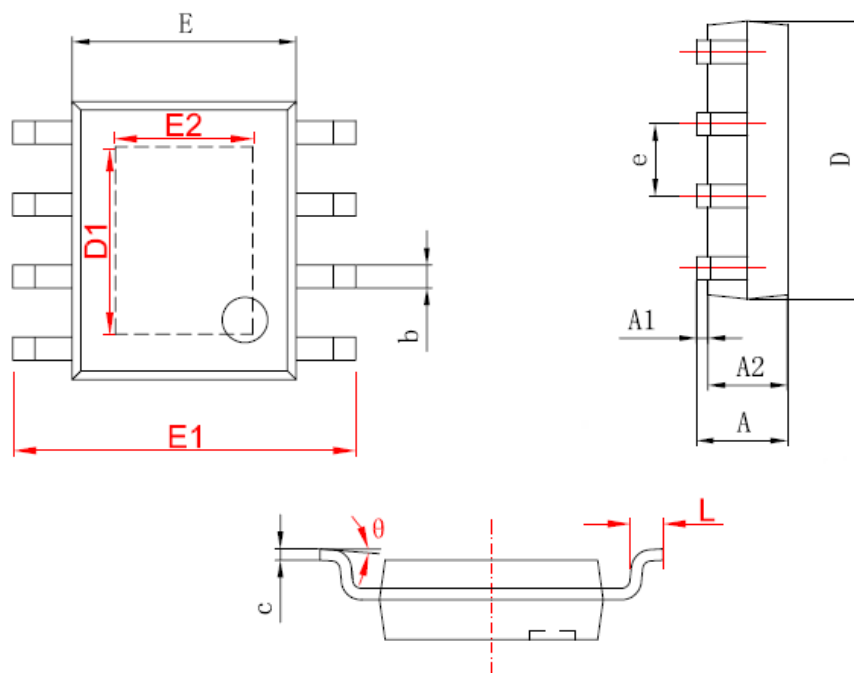

Figure10. XL7045 System Application (Efficiency VS Output Current)

Package Information

SOP8-EP



| Symbol | Dimensions In Millimeters | | Dimensions In Inches | |
|--------|---------------------------|-------|----------------------|-------|
| | Min. | Max. | Min. | Max. |
| A | 1.350 | 1.750 | 0.053 | 0.069 |
| A1 | 0.000 | 0.150 | 0.000 | 0.006 |
| A2 | 1.250 | 1.650 | 0.049 | 0.065 |
| b | 0.306 | 0.510 | 0.012 | 0.020 |
| c | 0.170 | 0.250 | 0.007 | 0.010 |
| D | 4.700 | 5.100 | 0.185 | 0.201 |
| D1 | 2.650 | 3.467 | 0.104 | 0.136 |
| E | 3.800 | 4.000 | 0.150 | 0.157 |
| E1 | 5.800 | 6.200 | 0.228 | 0.244 |
| E2 | 1.910 | 2.534 | 0.075 | 0.100 |
| e | 1.140 | 1.400 | 0.045 | 0.055 |
| L | 0.450 | 0.800 | 0.018 | 0.031 |
| θ | 0° | 8° | 0° | 8° |

| | |
|--|--------|
| 0.3A 100KHz 100V Buck DC to DC Converter | XL7045 |
|--|--------|

Important Notice

XLSEMI reserve the right to make modifications, enhancements, improvements, corrections or other changes without notice at any time. XLSEMI does not assume any liability arising out of the application or use of any product described herein; neither does it convey any license under its patent rights, nor the rights of others. XLSEMI assumes no liability for applications assistance or the design of Buyers' products. Buyers are responsible for their products and applications using XLSEMI components. To minimize the risks associated with Buyers' products and applications, Buyers should provide adequate design and operating safeguards. XLSEMI warrants performance of its products to the specifications applicable at the time of sale, in accordance with the warranty in XLSEMI's terms and conditions of sale of semiconductor products. Testing and other quality control techniques are used to the extent XLSEMI deems necessary to support this warranty. Except where mandated by applicable law, testing of all parameters of each component is not necessarily performed.

For the latest product information, go to www.xlsemi.com.